

# Hot Water Recirculating System

## Installation Instructions

Local codes or plumbing authority requirements may vary and take precedence over these instructions and diagrams provided below.

**⚠️ Recognize this symbol as an indication of important Safety Information.**

**⚠️ WARNING:** To avoid electrical shock, disconnect the power supply to water heater and circulator. Installation and service must be performed by a qualified installer or service agency.

**⚠️ WARNING:** It is very important that all persons who are expected to install the pump read these instructions along with the instructions provided with the tankless water heater.

**⚠️ CAUTION:** Recirculation pump is for residential potable water application only. Recirculation pump cannot be used with an air handler, boiler, spa, swimming pool, solar, closed system, or with multiple water heater installations. The maximum temperature setting is 140°F in recirculation system.

**⚠️ WARNING:** In the event the electrical box has been pulled off of the housing, DO NOT attempt to reattach it. Use of any other screw may short out the stator windings, creating a risk of electrical shock.

**⚠️ CAUTION:** When installing electrical connections, do not apply mechanical loads to the electrical box; otherwise, retaining screws may be pulled out of the housing, making circulator unusable.

### Shipment Information

Visually inspect the contents for any possible damage during shipment. Carefully remove pump from packaging so as not to drop the pump. Verify that all included supplied parts are present as shown.

Flange Gaskets - Qty 2

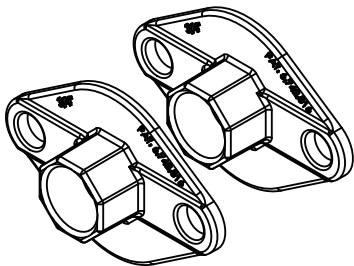
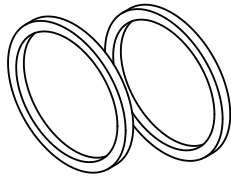

Stainless Steel Flange with 3/4" FNPT threads - Qty 2

7/16" -14 Bolts - Qty 4

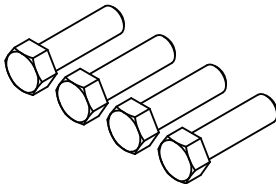

7/16" -14 Nuts - Qty 4

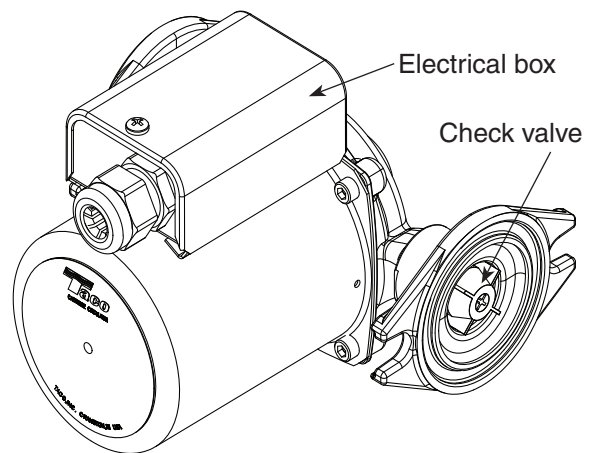
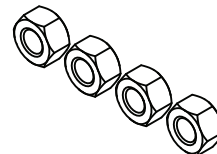

Recirculation Pump with built in check valve. (Supplied with power cord - not shown.) - Qty 1

## Pump Installation

**⚠ DO NOT install this pump outdoors. DO NOT energize pump until properly installed and system is checked for leak and completely filled.**

Pumps are designed to circulate water from 40°F to 150°F. Pump is rated for working pressure of 125psi. Electrical rating for pump is 115V, 1Ph, 60Hz.

**⚠ Pump is suitable for indoor application only.**

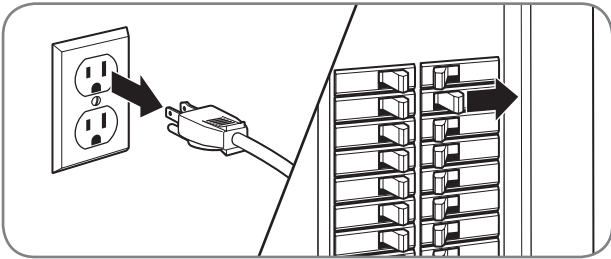

1. Turn remote control off, then disconnect electric power to water heater.

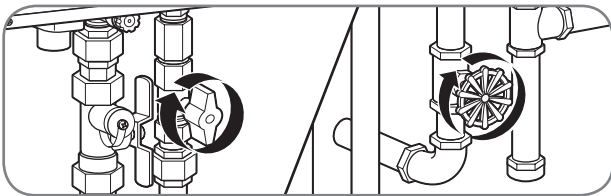

2. Shut off the gas and incoming water valves to the water heater.

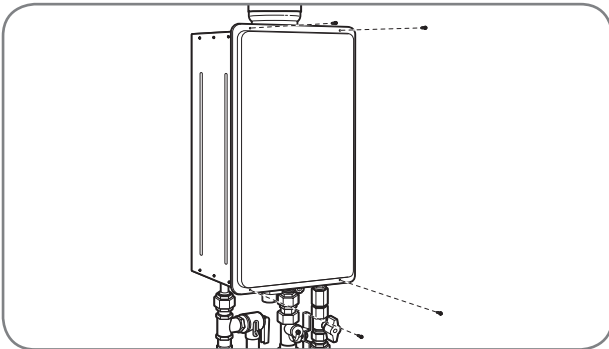

3. Remove the front cover panel on the water heater.

4. Install the pump according to the typical installation drawing shown on page 3.

**⚠ DO NOT install pump at the lowest point of the system where it can collect dirt and sediment.**

5. Lines should be cleaned and flushed prior to installing pump. Water should be treated if total hardness of water is 180 mg/L or higher so as not to affect performance of pump and water heater.

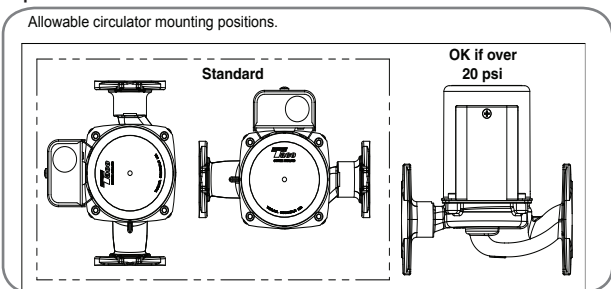

6. Pump can be used with tankless water heater and equivalent pipe length up to 400 ft. Equivalent pipe length includes fittings, supply and return piping. (Based on 3/4" diameter, L Type Copper Pipe).

7. Pump should be mounted such that the arrow at the bottom of the pump is pointing towards the heater. Pump must be mounted with the motor in a horizontal position. Pump can be installed with the shaft vertical or where the shaft falls below the horizontal plane if the system pressure is over 20 PSI.

8. The wire harness for the recirculation pump is bundled with the wire harness from the control board. Find a blue connector with a black and white wire and remove the female end of the connector by pressing on the release tab and pulling lightly.

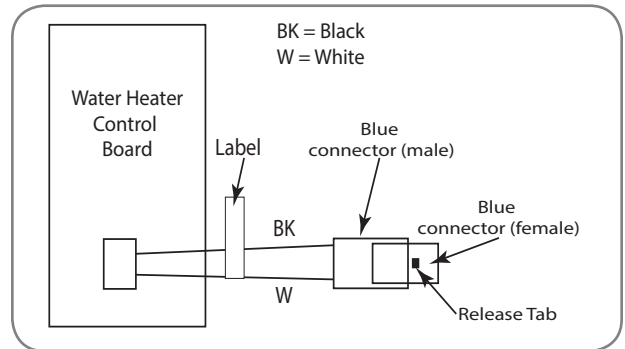

9. Locate the access hole at the bottom of the heater. Remove the rubber grommet in the access hole. Run the power cord through the access hole. Ensure strain relief is locked into the bottom panel of the water heater.

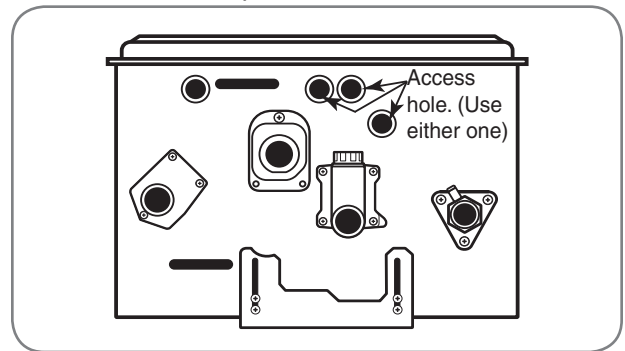

**⚠ WARNING: To avoid electrical shock, disconnect the power supply to the water heater at the main electrical unit.**

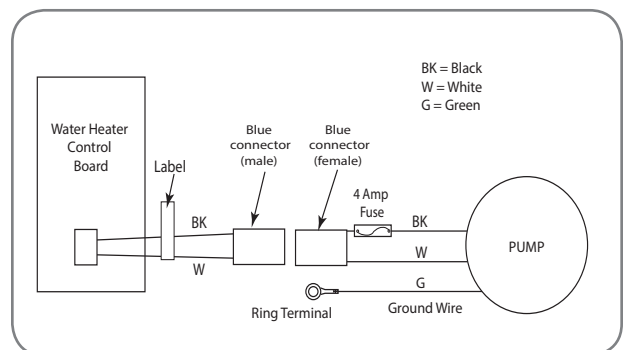

10. Connect the blue connector with black and white wires from pump to the blue connector inside the water heater.

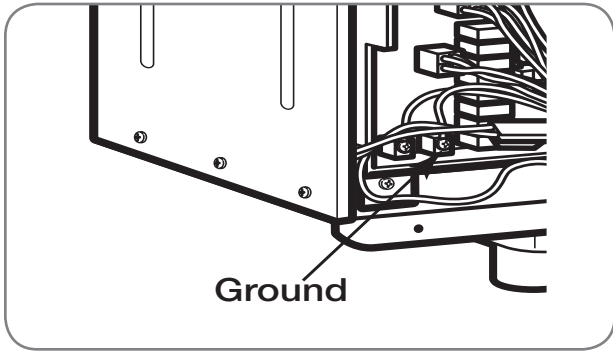

11. Connect the ground wire (green color wire) to the green screw at the base of the water heater control board.

**⚠️ Ensure pump is properly grounded per National Electrical Code and local codes or regulations. Ensure that water does not enter the terminal box during installation.**

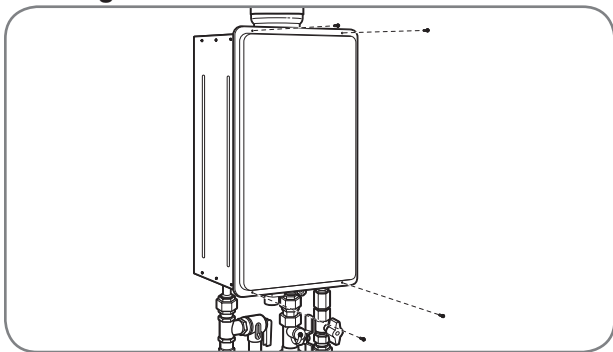

12. Replace the front cover panel.

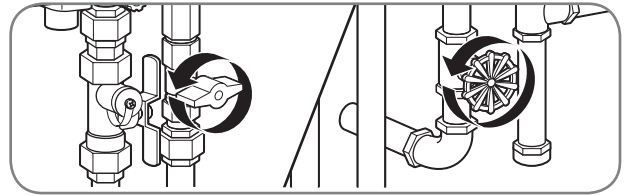

13. Open the gas and incoming water shut off valves.

14. **DO NOT** start the pump until the system has been filled and leak checked. Pump should be flooded with water before it is started.

**⚠️ Avoid running circulator pump dry as this will damage the circulator pump.**

15. Connect electric power to the water heater and turn on the remote control. The water heater and pump will turn on to raise the temperature of the recirculation loop.

16. **Follow the operating instructions provided with the water heater to set the DIP Switches on the control board of the water for proper operation of the recirculation system.** The table on page 4 provides the list of water heaters that have the recirculation logic feature.

## Typical Recirculating Pump Installation

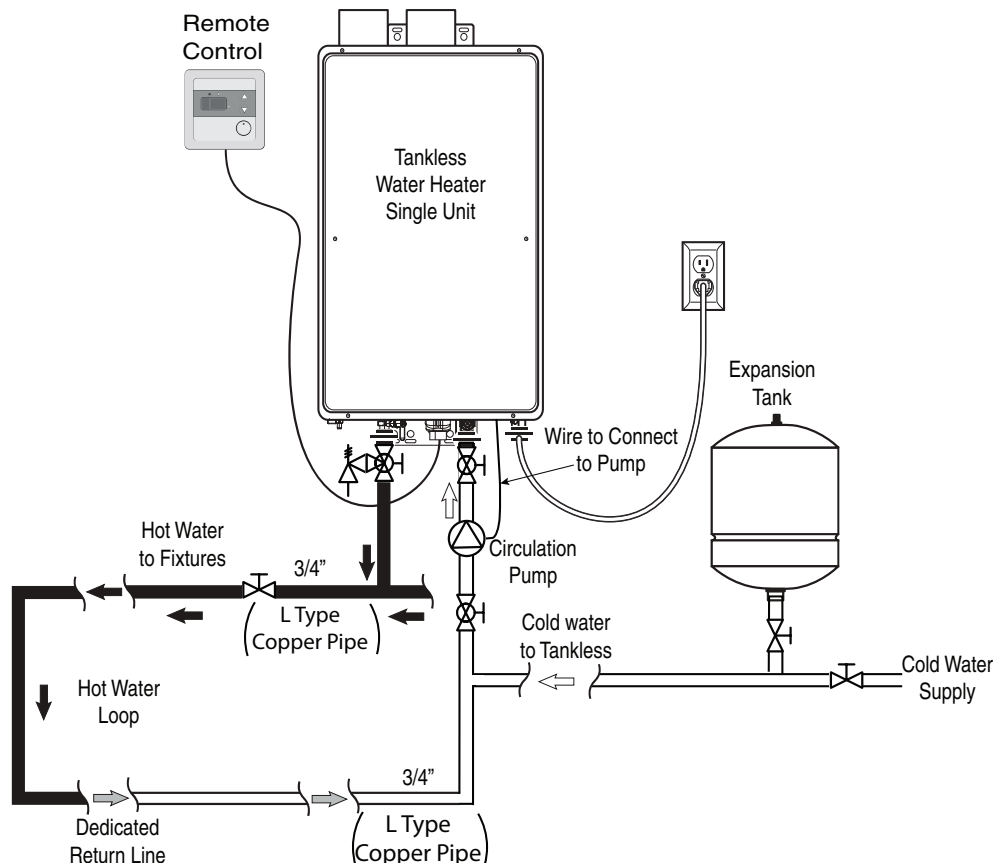

<b>Water Heater Models with Recirculation Logic</b>			
*RTG-95DVL/XL-1	PH2-28RDV/OF-1	ECO200DV/X3-1	NH-208DV/X-1
*RTG-84DVL/XL-1	PH2-25RDV/OF-1	ECO180DV/X3-1	NH-188DV/X-1
*RTG-64DVL/XL-1	PH2-20RDV/OF-1	ECO150DV/X3-1	
*RTGH-95DVL/XL-1	PHH-32RDV/OF-1	ECO180DV/X-1	NH-209DV/X-1
*RTGH-90DVL/XL-1		ECO180DV/X-1	
*RTGH-84DVL/XL-1	PHH-25RDV/OF-1	ECO160DV/X-1	NH-159DV/X-1
Some models could have "H" in model number to indicate high efficiency models.			
Applies to models with a suffix of "-1" or higher.			
*The model number "RTG" may be replaced with "RUTG" or RMTG"			
Recirculation logic applies to both NG and LP models.			

### **Important Warranty Information**

Taco, Inc. is the manufacturer of this product. All warranties are provided by Taco and Rheem Manufacturing Company makes no warranty whatsoever with respect to the product.

### **Taco Limited Warranty Information**

Taco, Inc. will repair or replace without charge (at the company's option) any Taco 00 Series circulator or circulator part which is proven defective under normal use within three (3) years from the date of manufacture.

In order to obtain service under this warranty, it is the responsibility of the purchaser to promptly notify the local Taco stocking distributor or Taco in writing and promptly deliver the subject product or part, delivery prepaid, to the stocking distributor. For assistance on warranty returns, the purchaser may either contact the local Taco stocking distributor or Taco. If the subject product or part contains no defect as covered in this warranty, the purchaser will be billed for parts and labor charges in effect at the time of factory examination and repair.

Any Taco product or part not installed or operated in conformity with Taco instructions or which has been subject to misuse, misapplication, the addition of petroleum-based fluids or certain chemical additives to the systems, or other abuse, will not be covered by this warranty.

If in doubt as to whether a particular substance is suitable for use with a Taco product or part, or for any application restrictions, consult the applicable Taco instruction sheets or contact Taco at (401-942-8000).

Taco reserves the right to provide replacement products and parts which are substantially similar in design and functionally equivalent to the defective product or part. Taco reserves the right to make changes in details of design, construction, or arrangement of materials of its products without notification.

**TACO OFFERS THIS WARRANTY IN LIEU OF ALL OTHER EXPRESS WARRANTIES. ANY WARRANTY IMPLIED BY LAW INCLUDING WARRANTIES OR MERCHANTABILITY OR FITNESS IS IN EFFECT ONLY FOR THE DURATION OF THE EXPRESS WARRANTY SET FORTH IN THE FIRST PARAGRAPH ABOVE.**

**THE ABOVE WARRANTIES ARE IN LIEU OF ALL WARRANTIES, EXPRESS OR STATUTORY, OR ANY OTHER WARRANTY OBLIGATION ON THE PART OF TACO.**

**TACO WILL NOT BE LIABLE FOR ANY SPECIAL, INCIDENTAL, INDIRECT OR CONSEQUENTIAL DAMAGES RESULTING FROM THE USE OF ITS PRODUCTS OR ANY INCIDENTAL COST OF REMOVING OR REPLACING DEFECTIVE PRODUCTS.**

This warranty gives the purchaser specific rights and the purchaser may have other rights which vary from state to state. Some state do not allow limitations on how long an implied warranty lasts or on the exclusion of incidental or consequential damages, so these limitations or exclusions may not apply to you.

This document contains Taco, Inc.'s logos and copyright materials.

Should you have any questions about this service part, or if it requires adjustment, repair, or routine maintenance, it is suggested that you first contact your installer, plumbing contractor or previously agreed upon service agency. In the event the firm has moved, or is unavailable, refer to the telephone directory, commercial listings or local utility for qualified service assistance.

Rheem Sales Company, Inc.  
1241 Carwood Court  
Montgomery, Alabama 36117  
Phone: 1-866-720-2076.