

Service and Troubleshooting

80% SINGLE STAGE ULTRA-LOW NOX GAS FURNACES A/GMES80*U* & A/GM9S80*U*

Pride and workmanship go into every product to provide our customers with quality products. It is possible, however, that during its lifetime a product may require service. Products should be serviced only by a qualified service technician who is familiar with the safety procedures required in the repair and who is equipped with the proper tools, parts, testing instruments and the appropriate service manual. **REVIEW ALL SERVICE INFORMATION IN THE APPROPRIATE SERVICE MANUAL BEFORE BEGINNING REPAIRS.**

TABLE OF CONTENTS

IMPORTANT INFORMATION.....	2
PRODUCT IDENTIFICATION.....	4
SYSTEM OPERATION.....	6
SCHEDULED MAINTENANCE.....	17
SERVICING.....	20
CHECKING VOLTAGE	21
CHECKING WIRING.....	21
CHECKING THERMOSTAT, WIRING.....	21
CHECKING TRANSFORMER AND CONTROL CIRCUIT.....	21
CHECKING AIR CIRCULATOR BLOWER MOTOR.....	22
CHECKING DUCT STATIC	22
CHECKING TEMPERATURE RISE.....	23
CHECKING PRIMARY LIMIT CONTROL	23
CHECKING AUXILIARY LIMIT CONTROL	24
INDUCED DRAFT BLOWER MOTOR	24
CHECKING GAS VALVE (REDUNDANT)	25
CHECKING GAS PRESSURE	25
CHECKING HOT SURFACE IGNITER.....	27
CHECKING PRESSURE TRANSDUCER.....	27
CHECKING FOR DELAYED IGNITION	28
CHECKING INTEGRATED IGNITION CONTROL BOARDS	28
CHECKING FLAME SENSOR	29
TROUBLESHOOTING CHART.....	30
WIRING DIAGRAMS.....	35



WARNING

ONLY PERSONNEL THAT HAVE BEEN TRAINED TO INSTALL, ADJUST, SERVICE, MAINTENANCE OR REPAIR (HEREINAFTER, "SERVICE") THE EQUIPMENT SPECIFIED IN THIS MANUAL SHOULD SERVICE THE EQUIPMENT. THE MANUFACTURER WILL NOT BE RESPONSIBLE FOR ANY INJURY OR PROPERTY DAMAGE ARISING FROM IMPROPER SERVICE OR SERVICE PROCEDURES. IF YOU SERVICE THIS UNIT, YOU ASSUME RESPONSIBILITY FOR ANY INJURY OR PROPERTY DAMAGE WHICH MAY RESULT. IN ADDITION, IN JURISDICTIONS THAT REQUIRE ONE OR MORE LICENSES TO SERVICE THE EQUIPMENT SPECIFIED IN THIS MANUAL, ONLY LICENSED PERSONNEL SHOULD SERVICE THE EQUIPMENT. IMPROPER INSTALLATION, ADJUSTMENT, SERVICING, MAINTENANCE OR REPAIR OF THE EQUIPMENT SPECIFIED IN THIS MANUAL, OR ATTEMPTING TO INSTALL, ADJUST, SERVICE OR REPAIR THE EQUIPMENT SPECIFIED IN THIS MANUAL WITHOUT PROPER TRAINING MAY RESULT IN PRODUCT DAMAGE, PROPERTY DAMAGE, PERSONAL INJURY OR DEATH.



WARNING

DO NOT BYPASS SAFETY DEVICES.

RS6621006r3
July 2022

IMPORTANT INFORMATION

IMPORTANT NOTICES

RECOGNIZE SAFETY SYMBOLS, WORDS AND LABELS

Pride and workmanship go into every product to provide our customers with quality products. It is possible, however, that during its lifetime a product may require service. Products should be serviced only by a qualified service technician who is familiar with the safety procedures required in the repair and who is equipped with the proper tools, parts, testing instruments and the appropriate service manual. **REVIEW ALL SERVICE INFORMATION IN THE APPROPRIATE SERVICE MANUAL BEFORE BEGINNING REPAIRS.**



WARNING

THIS UNIT SHOULD NOT BE CONNECTED TO, OR USED IN CONJUNCTION WITH, ANY DEVICES THAT ARE NOT DESIGN CERTIFIED FOR USE WITH THIS UNIT OR HAVE NOT BEEN TESTED AND APPROVED BY THE MANUFACTURER. SERIOUS PROPERTY DAMAGE OR PERSONAL INJURY, REDUCED UNIT PERFORMANCE AND/OR HAZARDOUS CONDITIONS MAY RESULT FROM THE USE OF DEVICES THAT HAVE NOT BEEN APPROVED OR CERTIFIED BY THE MANUFACTURER.



WARNING

TO PREVENT THE RISK OF PROPERTY DAMAGE, PERSONAL INJURY, OR DEATH. DO NOT STORE COMBUSTIBLE MATERIALS OR USE GASOLINE OR OTHER FLAMMABLE LIQUIDS OR VAPORS IN THE VICINITY OF THIS APPLIANCE.



WARNING

HIGH VOLTAGE!
DISCONNECT ALL POWER BEFORE SERVICING OR INSTALLING THIS UNIT. MULTIPLE POWER SOURCES MAY BE PRESENT. FAILURE TO DO SO MAY CAUSE PROPERTY DAMAGE, PERSONAL INJURY OR DEATH.



OUTSIDE THE U.S., call 1-713-861-2500.

(Not a technical assistance line for dealers.) Your telephone company will bill you for the call.

IMPORTANT INFORMATION



WARNING

IF THE INFORMATION IN THESE INSTRUCTIONS IS NOT FOLLOWED EXACTLY, A FIRE OR EXPLOSION MAY RESULT CAUSING PROPERTY DAMAGE, PERSONAL INJURY OR LOSS OF LIFE.

- DO NOT STORE OR USE GASOLINE OR OTHER FLAMMABLE VAPORS AND LIQUIDS IN THE VICINITY OF THIS OR ANY OTHER APPLIANCE.

- WHAT TO DO IF YOU SMELL GAS:

DO NOT TRY TO LIGHT ANY APPLIANCE.

DO NOT TOUCH ANY ELECTRICAL SWITCH; DO NOT USE ANY PHONE IN YOUR BUILDING.

IMMEDIATELY CALL YOUR GAS SUPPLIER FROM A NEIGHBOR'S PHONE. FOLLOW THE GAS SUPPLIER'S INSTRUCTIONS.

IF YOU CANNOT REACH YOUR GAS SUPPLIER, CALL THE FIRE DEPARTMENT.

- INSTALLATION AND SERVICE MUST BE PERFORMED BY A QUALIFIED INSTALLER, SERVICE AGENCY OR THE GAS SUPPLIER.



WARNING

SHOULD OVERHEATING OCCUR OR THE GAS SUPPLY FAIL TO SHUT OFF, TURN OFF THE MANUAL GAS SHUTOFF VALVE EXTERNAL TO THE FURNACE BEFORE TURNING OFF THE ELECTRICAL SUPPLY.



DANGER
PELIGRO



CARBON MONOXIDE POISONING HAZARD

Special Warning for Installation of Furnace or Air Handling Units in Enclosed Areas such as Garages, Utility Rooms or Parking Areas

Carbon monoxide producing devices (such as an automobile, space heater, gas water heater, etc.) should not be operated in enclosed areas such as unventilated garages, utility rooms or parking areas because of the danger of carbon monoxide (CO) poisoning resulting from the exhaust emissions. If a furnace or air handler is installed in an enclosed area such as a garage, utility room or parking area and a carbon monoxide producing device is operated therein, there must be adequate, direct outside ventilation.

This ventilation is necessary to avoid the danger of CO poisoning which can occur if a carbon monoxide producing device continues to operate in the enclosed area. Carbon monoxide emissions can be (re)circulated throughout the structure if the furnace or air handler is operating in any mode.

CO can cause serious illness including permanent brain damage or death.

B10259-216

RIESGO DE INTOXICACIÓN POR MONÓXIDO DE CARBONO

Advertencia especial para la instalación de calentadores ó manejadoras de aire en áreas cerradas como estacionamientos ó cuartos de servicio.

Los equipos ó aparatos que producen monóxido de carbono (tal como automóvil, calentador de gas, calentador de agua por medio de gas, etc) no deben ser operados en áreas cerradas debido al riesgo de envenenamiento por monóxido de carbono (CO) que resulta de las emisiones de gases de combustión. Si el equipo ó aparato se opera en dichas áreas, debe existir una adecuada ventilación directa al exterior. Esta ventilación es necesaria para evitar el peligro de envenenamiento por CO, que puede ocurrir si un dispositivo que produce monóxido de carbono sigue operando en el lugar cerrado.

Las emisiones de monóxido de carbono pueden circular a través del aparato cuando se opera en cualquier modo.

El monóxido de carbono puede causar enfermedades severas como daño cerebral permanente ó muerte.

B10259-216

RISQUE D'EMPOISONNEMENT AU MONOXYDE DE CARBONE

Avertissement special au sujet de l'installation d'appareils de chauffage ou de traitement d'air dans des endroits clos, tels les garages, les locaux d'entretien et les stationnements.

Evitez de mettre en marche les appareils produisant du monoxyde de carbone (tels que les automobile, les appareils de chauffage autonome, etc.) dans des endroits non ventilés tels que les d'empoisonnement au monoxyde de carbone. Si vous devez faire fonctionner ces appareils dans un endroit clos, assurez-vous qu'il y ait une ventilation directe provenant de l'exterieur.

Cette ventilation est nécessaire pour éviter le danger d'intoxication au CO pouvant survenir si un appareil produisant du monoxyde de carbone continue de fonctionner au sein de la zone confinée.

Les émissions de monoxyde de carbone peuvent être recirculés dans les endroits clos, si l'appareil de chauffage ou de traitement d'air sont en marche.

Le monoxyde de carbone peut causer des maladies graves telles que des dommages permanents au cerveau et même la mort.

B10259-216

PRODUCT IDENTIFICATION

NOMENCLATURE

The model and manufacturing number are used for positive identification of component parts used in manufacturing. Please use these numbers when requesting service or parts information.

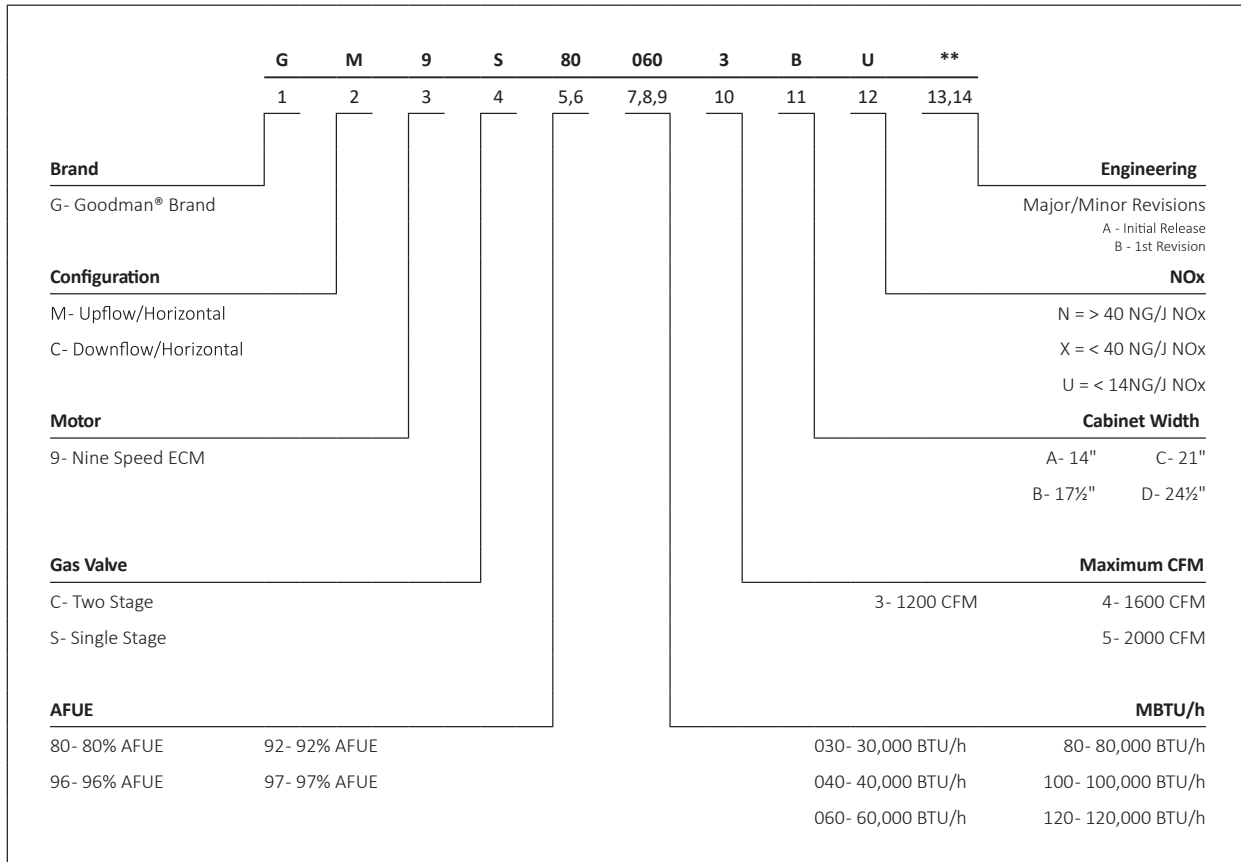
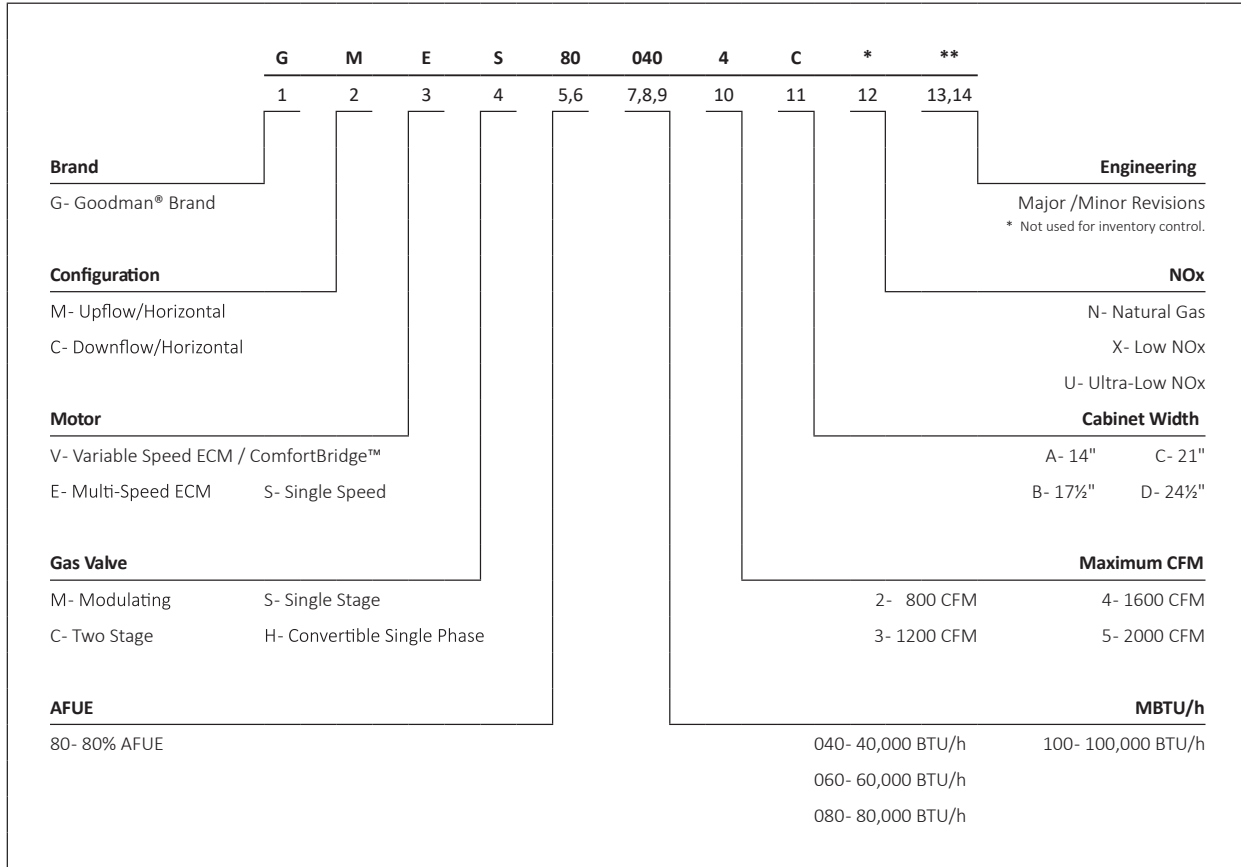

PRODUCT IDENTIFICATION

NOMENCLATURE

The model and manufacturing number are used for positive identification of component parts used in manufacturing. Please use these numbers when requesting service or parts information.

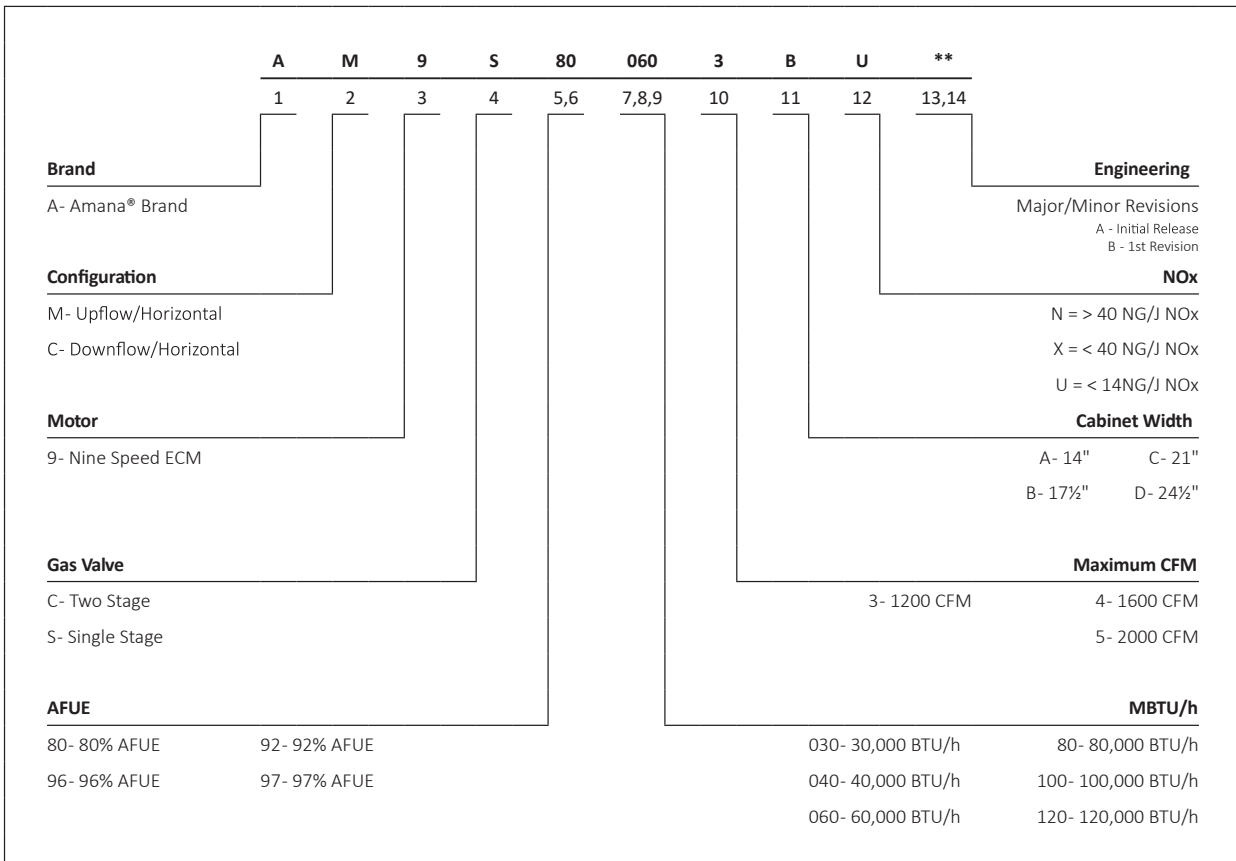
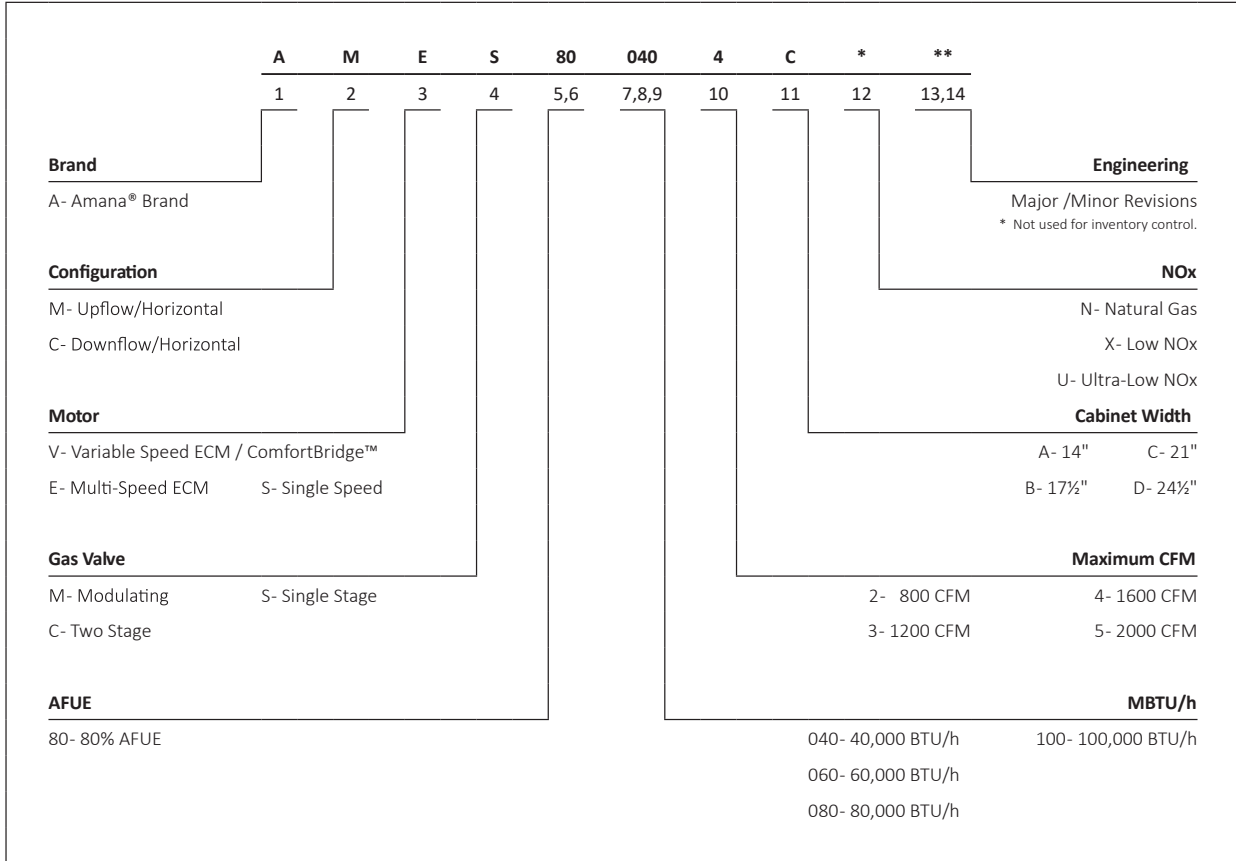

SYSTEM OPERATION

SAFETY

Please adhere to the following warnings and cautions when installing, adjusting, altering, servicing, or operating the furnace.



WARNING

TO PREVENT PERSONAL INJURY OR DEATH DUE TO IMPROPER INSTALLATION, ADJUSTMENT, ALTERATION, SERVICE OR MAINTENANCE, REFER TO THIS MANUAL. FOR ADDITIONAL ASSISTANCE OR INFORMATION, CONSULT A QUALIFIED INSTALLER, SERVICE AGENCY OR THE GAS SUPPLIER.



WARNING

TO PREVENT POSSIBLE PROPERTY DAMAGE, PERSONAL INJURY OR DEATH DUE TO ELECTRICAL SHOCK, THE FURNACE MUST BE LOCATED TO PROTECT THE ELECTRICAL COMPONENTS FROM WATER.

CHARGE (ESD) PRECAUTIONS

NOTE: Discharge your body's static electricity before touching unit. An electrostatic discharge can adversely affect electrical components.

Use the following precautions during furnace installation and servicing to protect the integrated control module from damage. By putting the furnace, the control, and the person at the same electrostatic potential, these steps will help avoid exposing the integrated control module to electrostatic discharge. This procedure is applicable to both installed and uninstalled (ungrounded) furnaces.

1. Disconnect all power to the furnace. Do not touch the integrated control module or any wire connected to the control prior to discharging your body's electrostatic charge to ground.
2. Firmly touch a clean, unpainted, metal surface of the furnace near the control. Any tools held in a person's hand during grounding will be discharged.
3. Service integrated control module or connecting wiring following the discharge process in Step 2. Use caution not to recharge your body with static electricity; (i.e., do not move or shuffle your feet, do not touch ungrounded objects, etc.). If you come in contact with an ungrounded object, repeat Step 2 before touching control or wires.
4. Discharge any static electricity from your body to ground before removing a new control from its container. Follow Steps 1 through 3 if installing the control on a furnace. Return any old or new controls to their containers before touching any ungrounded object.

Product Application

This product is designed for NATURAL GAS ONLY. This product is designed for use as a residential home gas furnace. It is **not** designed or certified for use in mobile home, trailer, or recreational vehicle applications.

IMPORTANT NOTE: The 80% furnace cannot be installed as a direct vent (i.e., sealed combustion) furnace. The burner box is present only to help reduce sound transmission from the burners to the occupied space.

To ensure proper installation, operation and servicing, thoroughly read the installation and service manuals for specifics pertaining to the installation, servicing and application of this product.



WARNING

POSSIBLE PROPERTY DAMAGE, PERSONAL INJURY OR DEATH DUE TO FIRE, EXPLOSION, SMOKE, SOOT, CONDENSATION, ELECTRICAL SHOCK OR CARBON MONOXIDE MAY RESULT FROM IMPROPER INSTALLATION, REPAIR, OPERATION OR MAINTENANCE OF THIS PRODUCT.



WARNING

TO PREVENT PROPERTY DAMAGE, PERSONAL INJURY OR DEATH DUE TO FIRE, DO NOT INSTALL THIS FURNACE IN A MOBILE HOME, TRAILER, OR RECREATIONAL VEHICLE.

To ensure proper furnace operation, install, operate, maintain and service the furnace in accordance with the installation, operation and service instructions, all local building codes and ordinances. In their absence, follow the latest edition of the National Fuel Gas Code (NFPA 54/ANSI Z223.1), and/or CAN/CGA B149 Installation Codes, local plumbing or waste water codes, and other applicable codes.

The rated heating capacity of the furnace should be greater than or equal to the total heat loss of the area to be heated. The total heat loss should be calculated by an approved method or in accordance with "ASHRAE Guide" or "Manual J-Load Calculations" published by the Air Conditioning Contractors of America.



WARNING

UPON COMPLETION OF THE FURNACE INSTALLATION, CAREFULLY INSPECT THE FLUE SYSTEM BOTH INSIDE AND OUTSIDE THE FURNACE TO ASSURE IT IS PROPERLY SEALED. LEAKS IN THE FLUE SYSTEM CAN RESULT IN SERIOUS PERSONAL INJURY OR DEATH DUE TO EXPOSURE TO FLUE PRODUCTS, INCLUDING CARBON MONOXIDE.

GAS SUPPLY AND PIPING

The furnace rating plate includes the approved furnace gas input rating and gas types. The furnace must be equipped to operate on the type of gas applied. This includes any conversion kits required for alternate fuels and/or high altitude.

SYSTEM OPERATION



CAUTION

TO PREVENT UNRELIABLE OPERATION OF EQUIPMENT DAMAGE, THE INLET GAS SUPPLY PRESSURE MUST BE AS SPECIFIED ON THE UNIT RATING PLATE WITH ALL OTHER HOUSEHOLD GAS FIRED APPLIANCES OPERATING.

Inlet gas supply pressures must be maintained within the ranges specified below. The supply pressure must be constant and available with all other household gas fired appliances operating. The minimum gas supply pressure must be maintained to prevent unreliable ignition. The maximum must not be exceeded to prevent unit overfiring.

INLET GAS SUPPLY PRESSURE

Natural Gas	Minimum: 4.5" w.c.	Maximum: 10.0" w.c.
-------------	--------------------	---------------------

GAS VALVE

This unit is equipped with a 24 volt gas valve controlled during furnace operation by the integrated control module. Taps for measuring the gas supply pressure and manifold pressure are provided on the valve.

NOTE: The gas supply pressure on White-Rodger "J" model gas valve, used on single stage furnaces, can be checked with a gas pressure test kit (Part #0151K0000S) available through our authorized distributors.

The gas valve has a manual ON/OFF control located on the valve itself. This control may be set only to the "ON" or "OFF" position. Refer to the *Lighting Instructions Label* section of this manual or the installation instructions for use of this control during start up and shut down periods.

GAS PIPING CONNECTIONS



CAUTION

TO AVOID POSSIBLE UNSATISFACTORY OPERATION OR EQUIPMENT DAMAGE DUE TO UNDERFIRING OF EQUIPMENT, USE THE PROPER SIZE OF NATURAL GAS PIPING NEEDED WHEN RUNNING PIPE FROM THE METER TO THE FURNACE.

The gas piping supplying the furnace must be properly sized based on the gas flow required, specific gravity of the gas, and length of the run. The gas line installation must comply with local codes, or in their absence, with the latest edition of the National Fuel Gas Code, NFPA 54/ANSI Z223.1.

Natural Gas Capacity of Pipe In Cubic Feet of Gas Per Hour (CFH)

Length of Pipe in Feet	Nominal Black Pipe Size				
	1/2"	3/4"	1"	1 1/4"	1 1/2"
10	132	278	520	1050	1600
20	92	190	350	730	1100
30	73	152	285	590	980
40	63	130	245	500	760
50	56	115	215	440	670
60	50	105	195	400	610
70	46	96	180	370	560
80	43	90	170	350	530
90	40	84	160	320	490
100	38	79	150	305	460

(Pressure 0.5 psig or less and pressure drop of 0.3" W.C.; Based on 0.60 Specific Gravity Gas)

CFH = $\frac{\text{BTUH Furnace Input}}{\text{Heating Value of Gas (BTU/Cubic Foot)}}$



CAUTION

EDGES OF SHEET METAL HOLES MAY BE SHARP. USE GLOVES AS A PRECAUTION WHEN REMOVING HOLE PLUGS.

GAS PIPING CHECKS

Before placing unit in operation or upon completion of servicing, leak test the unit and gas connections.



WARNING

TO AVOID THE POSSIBILITY OF EXPLOSION OR FIRE, NEVER USE A MATCH OR OPEN FLAME TO TEST FOR LEAKS.

Check for leaks using an approved chloride-free soap and water solution, an electronic combustible gas detector, or other approved testing methods.

NOTE: Never exceed specified pressures for testing. Higher pressure may damage the gas valve and cause subsequent overfiring, resulting in heat exchanger failure. Disconnect this unit and shutoff valve from the gas supply piping system before pressure testing the supply piping system with pressures in excess of 1/2 psig (3.48 kPa). Isolate this unit from the gas supply piping system by closing its external manual gas shutoff valve before pressure testing supply piping system with test pressures equal to or less than 1/2 psig (3.48 kPa).



WARNING

AN UNDETECTED GAS LEAK WILL CREATE A DANGER OR EXPLOSION OR FIRE. IF THE PRESENCE OF GAS IS SUSPECTED, FOLLOW THE INSTRUCTIONS ON THE COVER OF THIS MANUAL. FAILURE TO DO SO COULD RESULT IN SERIOUS PERSONAL INJURY OR DEATH.

SYSTEM OPERATION

 WARNING
<p>IF THE INFORMATION IN THESE INSTRUCTIONS IS NOT FOLLOWED EXACTLY, A FIRE OR EXPLOSION MAY RESULT CAUSING PROPERTY DAMAGE, PERSONAL INJURY OR LOSS OF LIFE.</p> <p>- DO NOT STORE OR USE GASOLINE OR OTHER FLAMMABLE VAPORS AND LIQUIDS IN THE VICINITY OF THIS OR ANY OTHER APPLIANCE.</p> <p>- WHAT TO DO IF YOU SMELL GAS: DO NOT TRY TO LIGHT ANY APPLIANCE. DO NOT TOUCH ANY ELECTRICAL SWITCH; DO NOT USE ANY PHONE IN YOUR BUILDING. IMMEDIATELY CALL YOUR GAS SUPPLIER FROM A NEIGHBOR'S PHONE. FOLLOW THE GAS SUPPLIER'S INSTRUCTIONS. IF YOU CANNOT REACH YOUR GAS SUPPLIER, CALL THE FIRE DEPARTMENT.</p> <p>- INSTALLATION AND SERVICE MUST BE PERFORMED BY A QUALIFIED INSTALLER, SERVICE AGENCY OR THE GAS SUPPLIER.</p>

HIGH ALTITUDE DERATE

The furnace, as shipped, requires no change to run between 0-4500 feet. At all altitudes the air temperature rise must be within the range listed on the Specification Sheet applicable to your model for the fuel used. Manifold pressure adjustments and combustion analysis are required for all installations above 4500 ft. Refer to "Gas Supply Pressure Measurement" section for instruction on how to properly measure and adjust manifold "outlet" pressure. The furnace should operate for a minimum of 15 minutes before taking a combustion sample. Combustion samples should be taken from beyond the furnace exhaust and must be within provided CO₂% range. See table below for recommended manifold pressure adjustments and proper CO₂% range. Gas heating values can vary; further pressure adjustment may be necessary to ensure furnace operates within acceptable CO₂ range.

MODEL	Manifold Pressure at 5000 ft	Manifold Pressure at 7500 ft	CO ₂ % Natural Gas
040	2.5" w.c.	2.4" w.c.	5.5 - 7.0
060	2.5" w.c.	2.4" w.c.	5.7 - 7.2
080	2.5" w.c.	2.4" w.c.	6.0 - 7.5



For *MES80 80% ULN Single Stage models you will also need the appropriate ID plug update. These ID plugs update the furnace parameters to allow it to function properly at High Altitude. ULN Single Stage 80% furnaces with serial numbers 2004 and after are approved for High Altitude installation without the ID plug update. ULN 80% furnace with serial numbers 2003 and prior will need this ID plug to operate at High Altitude. You will still need to adjust manifold pressures and CO₂% as described above. See the table below for the corresponding model number to ID Plug part number.

Goodman Model	80% ULN ID Plugs Not rated for high altitude	80% ULN ID Plugs Rated for altitude up to 7500 ft
GMES800403AU	0130F00773	0130F00785
GMES800603BU	0130F00765	0130F00787
GMES800604BU	0130F00766	0130F00788
GMES800804BU	0130F00767	0130F00789
GMES800805CU	0130F00768	0130F00790

NOTE: An optional kit is available (TSRK02) to provide low and high cooling speeds to support operation of a two stage cooling unit

ELECTRICAL CONNECTIONS

 WARNING
<p>TO AVOID THE RISK OF ELECTRICAL SHOCK, WIRING TO THE UNIT MUST BE PROPERLY POLARIZED AND GROUNDED.</p>

 WARNING
<p>HIGH VOLTAGE! DISCONNECT ALL POWER BEFORE SERVICING OR INSTALLING THIS UNIT. MULTIPLE POWER SOURCES MAY BE PRESENT. FAILURE TO DO SO MAY CAUSE PROPERTY DAMAGE, PERSONAL INJURY OR DEATH.</p>

 CAUTION
<p>LABEL ALL WIRES PRIOR TO DISCONNECTION WHEN SERVICING CONTROLS. WIRING ERRORS CAN CAUSE IMPROPER AND DANGEROUS OPERATION. VERIFY PROPER OPERATION AFTER SERVICING.</p>

WIRING HARNESS

The wiring harness is an integral part of this furnace. Field alteration to comply with electrical codes should not be required. Wires are color coded for identification purposes. Refer to the wiring diagram for wire routings. If any of the original wire as supplied with the furnace must be replaced, it must be replaced with wiring material having a temperature rating of at least 105°C. Any replacement wiring must be copper conductor.

115 VOLT LINE CONNECTIONS

Before proceeding with electrical connections, ensure that the supply voltage, frequency, and phase correspond to that specified on the unit rating plate. Power supply to the furnace must be N.E.C. Class 1, and must comply with all applicable codes. The furnace must be electrically grounded in accordance with local codes or, in their absence, with the latest edition of The National Electric Code, ANSI NFPA 70 and/or The Canadian Electric Code CSA C22.1.

SYSTEM OPERATION

Use a separate fused branch electrical circuit containing properly sized wire, and fuse or circuit breaker. The fuse or circuit breaker must be sized in accordance with the maximum overcurrent protection specified on the unit rating plate. An electrical disconnect must be provided at the furnace location.

NOTE: Line polarity must be observed when making field connections.

Connect hot, neutral, and ground wires as shown in the wiring diagram located on the unit's blower door. Metal conduit is not considered a substitute for an actual ground wire to the unit. Line polarity must be observed when making field connections. Line voltage connections can be made through either the right or left side panel.

CAUTION

EDGES OF SHEET METAL HOLES MAY BE SHARP. USE GLOVES AS A PRECAUTION WHEN REMOVING HOLE PLUGS.

NOTE: Wire routing must not interfere with circulator blower operation, filter removal, or routine maintenance.



WARNING

TO AVOID THE RISK OF ELECTRICAL SHOCK, INJURY, OR DEATH, THE FURNACE MUST BE ELECTRICALLY GROUNDED IN ACCORDANCE WITH LOCAL CODES OR, IN THEIR ABSENCE, WITH THE LATEST EDITION OF THE NATIONAL ELECTRIC CODE.

115 VOLT LINE CONNECTION OF ACCESSORIES (HUMIDIFIER AND ELECTRONIC AIR CLEANER)



WARNING

HIGH VOLTAGE!
DISCONNECT ALL POWER BEFORE SERVICING OR INSTALLING THIS UNIT. MULTIPLE POWER SOURCES MAY BE PRESENT. FAILURE TO DO SO MAY CAUSE PROPERTY DAMAGE, PERSONAL INJURY OR DEATH.

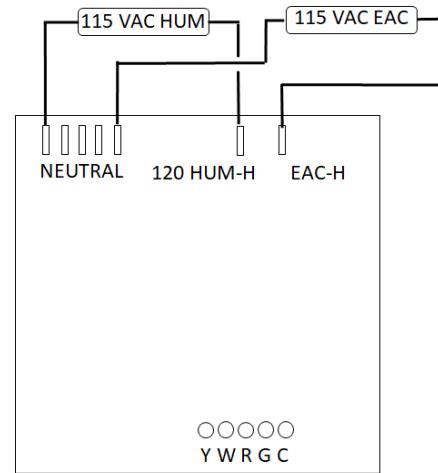

HUMIDIFIER WIRING

Accessory wiring connections are to be made through the ¼" quick connect terminals provided on the furnace integrated control module. The Humidifier and Electronic Air Cleaner hot and neutral terminals are identified as HUM and EAC. All field wiring must conform to applicable codes. Connections should be made as shown below.



Accessory Wiring

If it is necessary for the installer to supply additional line voltage wiring to the inside of the furnace, the wiring must conform to all local codes, and have a minimum temperature rating of 105°C. All line voltage wire splices must be made inside the furnace junction box. The integrated control module humidifier terminals (HUM) are energized with 115 volts whenever the induced draft blower is energized. The integrated control module electronic air cleaner terminals (EAC) are energized with 115 volts whenever the circulator blower is energized.

24 VOLT THERMOSTAT WIRING

NOTE: Low voltage connections can be made through either the right or left side panel. Wire routing must not interfere with circulator blower operation, filter removal, or routine maintenance.

A 40 V.A. transformer and an integrated electronic control are built into the furnace to allow use with most cooling equipment. Consult the wiring diagram, located in the Technical Manual or on the blower door for further details of 115 Volt and 24 Volt wiring.

THERMOSTAT WIRING - SINGLE-STAGE

The following drawing illustrates the typical field wiring for a heat only single stage system and a single stage heating/cooling system. Refer to the following figures for proper connections to the integrated control module.

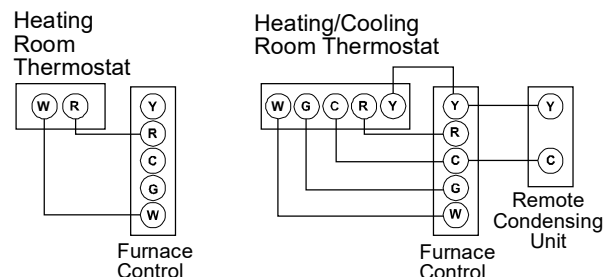

Typical Field Wiring (24 VAC Control Circuit)

SYSTEM OPERATION

*M9S80*UAA

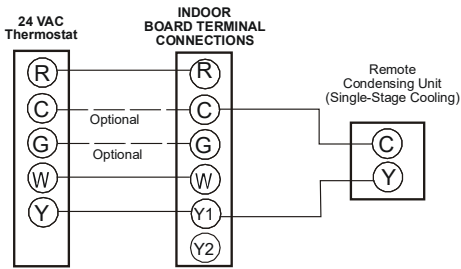

Non-communicating Single Stage A/C

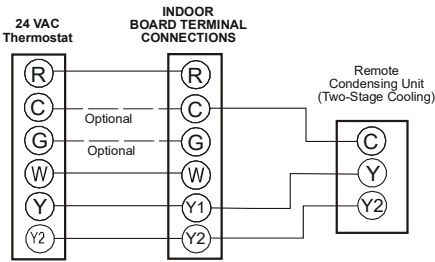

Non-communicating Two Stage A/C

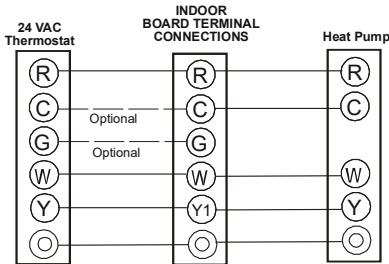

Non-Communicating Single Stage Heat Pump

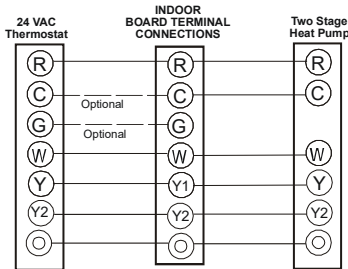

Non-Communicating Two Stage Heat Pump

CONTINUOUS FAN OPERATION

The single stage furnace control will energize the **heating** circulator fan speed when the fan switch on the thermostat is turned to the "ON" position.

CIRCULATOR BLOWER SPEED ADJUSTMENT

WARNING

HIGH VOLTAGE!
ELECTRICAL COMPONENTS ARE CONTAINED IN BOTH COMPARTMENTS. TO AVOID ELECTRICAL SHOCK, INJURY OR DEATH, DO NOT REMOVE ANY INTERNAL COMPARTMENT COVERS OR ATTEMPT ANY ADJUSTMENT. CONTACT A QUALIFIED SERVICE AGENT AT ONCE IF AN ABNORMAL FLAME APPEARANCE SHOULD DEVELOP.

For *MES80*UAA models, connect the correct motor leads to the COOL, HEAT, and PARK terminals. If the heating speed equals cooling speed, use the jumper wire provided. All unused motor leads that are not connected to "PARK" terminals on the control must be taped to prevent shorts.

***M9S80*U WITH PCBBF241 CONTROL BOARD**

Control Board Main Menu

Description	Main Menu LED Display	Option Menu LED Display	Default
Idle - system awaiting input	i dl		
Display Active Alarm	Er r	See Troubleshooting chart for alarm code definition	
Display Last 6 Faults	L6F		
Code Release Number	Cr	None	
Shared Data Revision	Sr	None	
Reset to Factory Default	r Fd	Yes / No	
Outdoor Setting Menu	OdS	AC1 / AC2 / HP1 / HP2 / OFF	OFF
Blower Speed for Continuous Fan Mode	FSd	F01 - F09	F01
Blower Speed for 1st Stage Compressor Mode	AC1	F01 - F09	Model specific
Blower Speed for 2nd Stage Compressor Mode	AC2	F01 - F09	Model specific
Cooling Fan Off Delay	CFd	0 - 120 seconds	65 seconds
Cooling Fan On Delay	Cnd	0 - 35 seconds	7 seconds
Blower Speed for Gas Heat Mode	gAF	Allowable speeds Fxx	Model specific
Gas Heat Off Delay	gFd	30 - 120 seconds	90 seconds
Gas Heat On Delay - locked	gnd	None	30 seconds
Blower Speed for 1st Stage HP Heat Mode	HP1	F01 - F09	Model specific
Blower Speed for 2nd Stage HP Heat Mode	HP2	F01 - F09	Model specific
HP Heat Off Delay	HFd	30 - 120 seconds	60 seconds
HP Heat On Delay	Hnd	5 - 30 seconds	5 seconds

SYSTEM OPERATION

Control Board Status Menu

LED Display	Description of System Status
888	All segments illuminated = control powering up
I DL	Idle
FAn	Constant Fan
1AC	Low Stage Cooling
2AC	High Stage Cooling
1AC	Compressor Heat, Low Stage
2AC	Compressor Heat, High Stage
gH	Gas Heat
1HP	Low Stage HP
2HP	High Stage HP
dFt	Defrost

QUICK START

Initial set up of outdoor systems are required to be configured through the control board. Navigate to OdS menu using the push buttons to properly configure the outdoor system. Selections for AC1, AC2, HP1, HP2 must be made to enable specific fan speeds and thermostat signals to function.

NOTE: Equipment type (Single-stage cooling, Two-stage cooling, Single-stage heat pump, Two-stage heat pump) MUST be setup through the OdS menu by the installer for proper system operation.

USING PUSH-BUTTON SWITCHES

All user settings may be accessed by two push-button switches on the control board. The switches are identified as “menu” & “option”. To enter the main menu, press the “menu” switch. Each time the menu switch is pressed the display will show the next available item in the main menu.

While in the main menu, press the “option” switch to scroll through available options corresponding to the main menu item displayed. In the option menu, the default option will be displayed first. If the default option has been changed to another option, the current option selection will be displayed first.

The option menu will display both adjustable & non-adjustable options. When an adjustable option is displayed, the display will flash continuously until a switch is pressed. If a non-adjustable option is displayed (such as Code Release Number) the display will not flash.

While navigating the option menus, press the menu switch to select the displayed option. The displayed selection will stop flashing indicating the selection was made. Press the menu button again to finalize the selection and return to the corresponding main menu.

In the option menu, after the last option has been displayed, the display will revert to the corresponding main menu & display the default (or selected) option. If switches are inactive for 30 seconds the display will revert to the status menu.

Continuous Fan Mode Speed Selection

To change the main blower speed in circulation mode, see the following steps:

1. Press menu button until LED displays “FSd”. Press option button and LED will display the currently selected speed number as Fxx (xx: Blower speed number from 1 to 9).
2. The control shall cycle through available fan speeds every time the option button is pressed. All 9 speeds are available for circulation.
3. When the menu button is pressed, the current displayed speed shall stop flashing. Press the menu button again to select the option and the control shall immediately apply that blower setting and return to the corresponding main menu.

THERMOSTAT CALL	AVAILABLE SPEEDS (FSd menu)
G	F01
	F02
	F03
	F04
	F05
	F06
	F07
	F08
	F09

Circulation Speed Table

COOLING MODE SPEED SELECTION

To change the main blower speed in COOLING mode, follow the following steps:

NOTE: If Heat Pump system is configured in OdS menu (HP1 or HP2) COOLING thermostat calls will include “Y1”/“Y2” + “O” terminals energized.

1. Press menu button until LED displays “AC1” (for single stage COOLING) or “AC2” (for Two stage COOLING). Press option button and the LED will display the currently selected speed number as Fxx (xx: Blower speed number from 1 to 9).
2. The control shall cycle through available fan speeds every time the option button is pressed. All 9 speeds are available for both Single and Two Stage cooling.

SYSTEM OPERATION

- When the menu button is pressed, the current displayed speed shall stop flashing. Press the menu button again to select the option and the control shall immediately apply that blower setting and return to the corresponding main menu.

THERMOSTAT CALL (OdS: Terminal)	AVAILABLE SPEEDS (AC1 menu)
1AC: Y1 1HP: Y1 + O	F01
	F02
	F03
	F04
	F05
	F06
	F07
	F08
	F09

Single Stage Cooling Speed Table

THERMOSTAT CALL (OdS: Terminal)	AVAILABLE SPEEDS (AC2 menu)
2AC: Y1 + Y2 2HP: Y1 + Y2 + O	F01
	F02
	F03
	F04
	F05
	F06
	F07
	F08
	F09

Two Stage Cooling Speed Table

GAS HEATING MODE SPEED SELECTION

To change the main blower speed in GAS HEATING mode, see the following steps:

- Press menu button until LED displays "gAF". Press option button and LED will display the currently selected fan speed as Fxx (xx: Blower speed number).
- The control shall cycle through available speed number every time the option button is pressed.
- When the menu button is pressed, the current displayed speed shall stop flashing. Press the menu button again to select the option and the control shall immediately apply that blower setting and return to the corresponding main menu.

NOTE: Each furnace model contains different allowable gas heating speeds. Allowable gas heating speeds will be visible within gAF fan speed menu.

Heat Pump Heating Mode Speed Selection

To change the main blower speed in Heat Pump HEATING mode, follow the following steps:

- Press menu button until LED displays "HP1" (for single stage HP HEATING) or "HP2" (for Two stage HP HEATING). Press option button and the LED will display the currently selected speed number as Fxx (xx: Blower speed number from 1 to 9).
- The control shall cycle through available fan speeds every time the option button is pressed. All 9 speeds are available for both Single and Two Stage HP HEATING.
- When the menu button is pressed, the current displayed speed shall be selected, and control shall apply the newly selected speed in next HP HEATING call.

THERMOSTAT CALL (OdS: Terminal)	AVAILABLE SPEEDS (HP1 menu)
1HP: Y1	F01
	F02
	F03
	F04
	F05
	F06
	F07
	F08
	F09

Single Stage HP Heating Speed Table

THERMOSTAT CALL (OdS: Terminal)	AVAILABLE SPEEDS (HP2 menu)
2HP: Y1 + Y2	F01
	F02
	F03
	F04
	F05
	F06
	F07
	F08
	F09

Two Stage HP Heating Speed Table

CIRCULATOR BLOWER FAN TIMING ADJUSTMENT

NOTE: Items in this section refer to the air circulator blower fan, NOT to the induced draft blower. The induced draft blower timing sequence is not adjustable.

The integrated control module on all models provides selectable fan on/off delay adjustments.

SYSTEM OPERATION

ON/OFF FAN DELAY SELECTION

To change the fan on or off delay for COOLING, HP HEATING & GAS HEATING modes, see the following steps:

1. Press menu button until LED displays the desired on/off setting (See MAIN MENU section for selectable blower on/off delay options). Press option button and LED will display the selected on/off delay time in seconds.
2. The control shall cycle through available on/off delay times every time the option button is pressed.
3. When the menu button is pressed, the current displayed on/off delay shall stop flashing. Press the menu button again to select the option and the control shall immediately apply that delay setting and return to the corresponding main menu.

CIRCULATING AIR AND FILTERS DUCTWORK - AIR FLOW

Duct systems and register sizes must be properly designed for the C.F.M. and external static pressure rating of the furnace. Ductwork should be designed in accordance with the recommended methods of "Air Conditioning Contractors of America" manual D.

A duct system should be installed in accordance with Standards of the National Board of Fire Underwriters for the Installation of Air Conditioning, Warm Air Heating and Ventilating Systems, Pamphlets No. 90A and 90B.

A return air filter is not supplied with the furnace. The installer or servicer must supply a means of filtering all of the return air. Filter(s) shall comply with UL900 or CAN/ULC-S111 Standards.

Upflow / Horizontal Models	Minimum Recommended Filter Size [^]
0403A	1 - 16 X 25 Side or 1 - 14 X 24 Bottom Return
0603A	1 - 16 X 25 Side or 1 - 14 X 24 Bottom Return
0604B	1 - 16 X 25 Side or Bottom Return
0804B	1 - 16 X 25 Side or Bottom Return
0805C	1 - 16 X 25 Side or Bottom Return ¹

[^] Larger filters may be used, filters may also be centrally located

¹ = use 2 - 16 X 25 filters and two side returns or 20 X 25 filter on bottom return if furnace is connected to a cooling unit over 4 tons nominal capacity

Upflow furnaces with air delivery of less than 1800 CFM:
Use one side return or one bottom return ductwork connection.

Upflow furnaces with air delivery of 1800 CFM or higher:
Use two side returns or bottom return or combination of side/bottom connection.

Guide dimples locate the side and bottom return cutout locations. Use a straight edge to scribe lines connecting the dimples. Cut out the opening on these lines. An undersized opening will cause reduced airflow. For bottom

return connection, remove the bottom of the cabinet before setting the furnace on the raised platform or return air duct.

A closed return duct system must be used, with the return duct connected to the furnace. **NOTE: Ductwork must never be attached to the back of the furnace.** Supply and return connections to the furnace may be made with flexible joints to reduce noise transmission, if desired. If a central return is used, a connecting duct must be installed between the unit and the utility room wall so the blower will not interfere with combustion air or draft. The room, closet, or alcove must not be used as a return air chamber.

When the furnace is used in connection with a cooling unit, the furnace should be installed in parallel with or on the upstream side of the cooling unit to avoid condensation in the heating element. With a parallel flow arrangement, the dampers or other means used to control the flow of air must be adequate to prevent chilled air from entering the furnace and, if manually operated, must be equipped with means to prevent operation of either unit unless the damper is in the full heat or cool position.

When the furnace is heating, the temperature of the return air entering the furnace must be between **55°F** and **100°F**.

UPRIGHT FILTER INSTALLATIONS

Depending on the installation and/or customer preference, differing filter arrangements can be applied. Filters can be installed in the central return register and a side panel external filter rack kit (upflow filter kit # EFR01). As an alternative a media air filter or electronic air cleaner can be used as the requested filter. Refer to the following minimum filter requirement charts for determination of the minimum filter area to ensure proper unit performance.

ADDITIONAL FILTERING ACCESSORIES EXTERNAL FILTER RACK KIT (EFR02)

The external filter rack kit is intended to provide a location external to the furnace casing, for installation of a permanent filter on upflow model furnaces. The rack is designed to mount over the indoor blower compartment area of either side panel, and provide filter retention as well as a location for attaching return air ductwork.

*MES80*UAA WITH PCBBF161 CONTROL BOARD

NORMAL SEQUENCE OF OPERATION

POWER UP

- 120 VAC power applied to furnace.
- Integrated ignition control performs internal checks.
- LED light will flash once at power up and then remain on.
- Integrated ignition control monitors safety circuit continuously.

SYSTEM OPERATION

- Furnace awaits call from thermostat.

HEATING MODE

The normal operational sequence in heating mode is as follows:

- R and W thermostat contacts close, initiating a call for heat.
- Integrated control module performs safety circuit checks.
- **Pressure Sensor Verification:** The control operates the inducer in a manner to verify the pressure sensor null value and span operation are within specification. If the system is operating correctly, this test takes only a few seconds. If the system is not functioning properly, the control times out after a maximum 90 seconds and display the proper fault code.
- Induced draft blower is energized for 30 second prepurge.
- Igniter warm up begins after 30 second prepurge expires.
- Gas valves open at end of igniter warm up period, delivering gas to burners and establishing flame.
- Integrated control module monitors flame presence. Gas valve will remain open only if flame is detected.
- Circulator blower is energized on high heat speed following a fixed 30 second blower on delay. Electronic air cleaner terminals are energized with circulator blower.
- Furnace operates; integrated control module monitors safety circuits continuously.
- R and W thermostat contacts open, completing the call for heat.
- Gas valve closes, extinguishing flame.
- Induced draft blower is de-energized following a thirty second post purge.
- HUM terminal is de-energized.
- Circulator blower continues running for selected heat off delay period factory set at 120 seconds. If required this can be changed in the field.
- Electronic air cleaner is de-energized.
- Furnace awaits the next call from thermostat.

COOLING MODE

The normal operational sequence in cooling mode is as follows:

- R, Y and G thermostat contacts close, initiating a call for cool.
- Integrated control module performs safety circuit checks.
- Outdoor fan and compressor are energized.
- Circulator blower is energized on cool speed following a fixed six second on delay. If required this can be changed in the field to 45 seconds. Electronic air cleaner terminals are energized with circulator blower.

- Furnace circulator blower and outdoor cooling unit run, integrated control module monitors safety circuits continuously.
- R, Y and G thermostat contacts open, completing the call for cool.
- Outdoor fan and compressor are de-energized.
- Circulator blower is de-energized following a fixed forty five second cool off delay period. Electronic air cleaner terminals are de-energized.
- Furnace awaits the next call from thermostat.

FAN ONLY MODE

The normal operational sequence in Fan Only Mode is as follows:

- R and G thermostat contacts close, initiating a call for fan.
- Integrated control module performs safety circuit checks.
- Circulator blower is energized on low heat speed. Electronic air cleaner terminals are energized.
- Circulator blower runs, integrated control module monitors safety circuits continuously.

ID PLUGS FOR *MES80*UAA ULN 80% FURNACE

Each 80% ULN model has a unique ID Plug that needs to be installed into the board for your specific model number. The ID plug will populate the board with the correct operating parameters for each model and should be left in the board once installed.:

Please see the table below for reference.

Part Number	Goodman / Amana
0130F00773	*MES800403AUAA
0130F00765	*MES800603AUAA
0130F00766	*MES800604BUAA
0130F00767	*MES800804BUAA
0130F00768	*MES800805CUAA

ID PLUG INSTALLATION

The following procedure will ensure the proper operating parameters are installed onto the board. Each model has a unique ID PLUG that needs to be installed into the board for your specific model number. Please see the instruction below.

1. Select the appropriate ID plug for the installed model number from the table above.
2. Attach the appropriate ID Plug for the installed model number to the control board into the blue connector as shown below. This will load the correct parameters to the board. Failure to follow these instructions will result in the board not functioning.

SYSTEM OPERATION

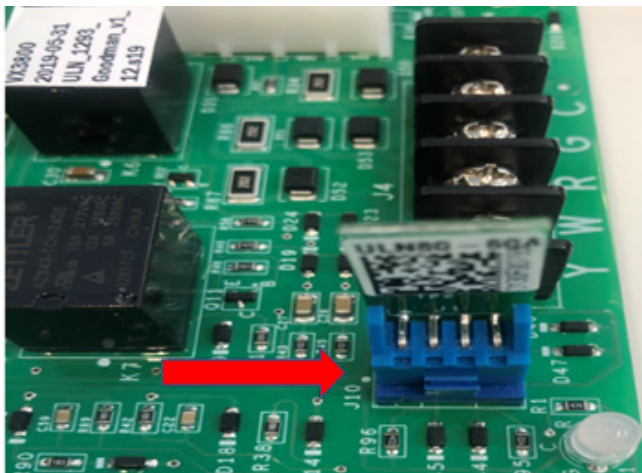

*M9S80*UAA WITH PCBBF241 CONTROL BOARD

COOLING MODE SEQUENCE OF OPERATION

1ST STAGE COOLING MODE SEQUENCE:

- On a call for low stage cooling, the Y1 or Y1 and G thermostat contacts close signaling the furnace control board with 24 vac. on Y1 or Y1 and G terminals.
- The 7-Segment will display: 1 A C
- The compressor and condenser fan are energized.
- The circulator fan is energized at low cool speed after the cool on delay period. The electronic air cleaner EAC relay will close the EAC contacts.
- After the thermostat is satisfied, the compressor is de-energized and the Cool Mode Fan Off Delay period begins.
- Following the Cool Mode Fan Off Delay period, the indoor fan and air cleaner relays are de-energized

2ND STAGE COOLING MODE SEQUENCE:

NOTE: A Y1 call must be present or a Y2 call will be ignored.

- On a call for 2nd stage cooling, the Y2 or Y2 and G thermostat contacts close signaling the furnace control board with 24 vac. on Y2 or Y2 and G terminals.
- The 7-Segment will display: 2 A C
- The compressor and condenser fan are energized.
- The circulator fan is energized at cool speed after a cool on delay. The electronic air cleaner EAC relay will close the EAC contacts.
- After the thermostat is satisfied, the compressor is de-energized and the Cool Mode Fan Off Delay period begins.
- Following the Cool Mode Fan Off Delay period, the indoor fan and air cleaner relays are de-energized.

HEAT PUMP MODE

1ST STAGE HP HEATING MODE SEQUENCE:

- On a call for low stage HP Heating, the Y1 or Y1 and G thermostat contacts close signaling the furnace control board with 24 vac. on Y1 or Y1 and G terminals.
- The 7-Segment will display: 1 H P
- The compressor and condenser fan are energized.
- The circulator fan is energized at HP1 fan speed after the HP on delay period. The electronic air cleaner, EAC, and humidifier, HUM, relays will close the contacts.
- After the thermostat is satisfied, the compressor is de-energized and the electronic air cleaner EAC and humidifier HUM relays de-energize. The HP Heat Mode Fan Off Delay period begins.
- Following the HP Heat Mode Fan Off Delay period, the indoor fan, EAC, & HUM relays are de-energized.

2ND STAGE HP HEATING MODE SEQUENCE:

NOTE: A Y1 call must be present or a Y2 call will be ignored.

- On a call for 2nd stage HP Heating, the Y2 or Y2 and G thermostat contacts close signaling the furnace control board with 24 vac. on Y2 or Y2 and G terminals.
- The 7-Segment will display: 2 H P
- The compressor and condenser fan are energized.
- The circulator fan is energized at HP2 fan speed after the HP on delay period. The electronic air cleaner EAC and humidifier HUM relays will close the contacts.
- After the thermostat is satisfied, the compressor is de-energized and the electronic air cleaner EAC and humidifier HUM relays de-energize. The HP Heat Mode Fan Off Delay period begins.
- Following the HP Heat Mode Fan Off Delay period, the indoor fan, EAC, & HUM relays are de-energized.

FAN ONLY MODE

The normal operational sequence in fan only mode is as follows:

- R and G thermostat contacts close, initiating a call for fan.
- Integrated control module performs safety circuit checks.
- Circulator blower is energized on user selected fan speed. Electronic air cleaner terminal relay is energized.

SYSTEM OPERATION

- Circulator blower runs, integrated control module monitors safety circuits continuously.
- R and G thermostat contacts open, completing the call for fan.
- Circulator blower is de-energized. Electronic air cleaner terminal relay is de-energized.
- Furnace awaits the next call from thermostat.

DEFROST MODE

Defrost call can only be generated with heat pump outdoor unit properly configured in the OdS menu.



- On a call for Defrost, the Y1 or Y1 with Y2 with/without O contacts and W thermostat contacts close signaling the furnace control board to enter defrost.
- If Y with O and W are present simultaneously, the blower shall be energized at Cooling Speed after COOL on delay, then, switch the blower speed to the Greater of (Cooling Speed or Gas Heat speed) after Gas Heat On Delay expired.
- If Y without O and W are present simultaneously, the blower shall be energized at HP Heat Speed after HP Heat On Delay, then, switch the blower speed to the Greater of (HP Heat Speed or Gas Heat speed) after Gas Heat On Delay expired.
- The 7-Segment will display: d F t
- The electronic air cleaner EAC and humidifier HUM relays will close the contacts.
- After the thermostat is satisfied, the gas valve will de-energize. The Gas Heat Mode Fan Off Delay period begins.
- Following the Gas Heat Mode Fan Off Delay period, the indoor fan, EAC, & HUM relays are de-energized.

GAS HEATING MODE

The normal operational sequence in gas heating mode is as follows:

- R and W thermostat contacts close, initiating a call for heat. The control will display heat mode in status menu: - g h
- Integrated control module performs safety circuit checks.
- Induced draft blower is energized for 30 second pre-purge period causing pressure sensor contacts to close.
- Igniter warm up begins after 30 second prepurge expires.
- Gas valve opens at end of igniter warm up period, delivering gas to burners and establishing flame.
- Integrated control module monitors flame presence. Gas valve will remain open only if flame is detected.
- Circulator blower is energized on user selected heat speed following a fixed thirty second blower on delay. Electronic air cleaner and humidifier terminal relays are energized with circulator blower.
- Furnace operates; integrated control module monitors safety circuits continuously.
- R and W thermostat contacts open, completing the call for heat.
- Gas valve closes, extinguishing flame.
- Induced draft blower is de-energized following a thirty second post purge.
- HUM terminal relay is de-energized.
- Circulator blower continues running for selected heat off delay. If required this can be changed in the field.
- Electronic air cleaner is de-energized.
- Furnace awaits the next call from thermostat.

SCHEDULED MAINTENANCE

 WARNING	
HIGH VOLTAGE! DISCONNECT ALL POWER BEFORE SERVICING OR INSTALLING THIS UNIT. MULTIPLE POWER SOURCES MAY BE PRESENT. FAILURE TO DO SO MAY CAUSE PROPERTY DAMAGE, PERSONAL INJURY OR DEATH.	
 CAUTION	
IF YOU MUST HANDLE THE IGNITOR, HANDLE WITH CARE. TOUCHING THE IGNITOR BODY WITH BARE FINGERS, ROUGH HANDLING, OR VIBRATION COULD RESULT IN EARLY IGNITOR FAILURE. ONLY A QUALIFIED SERVICER SHOULD EVER HANDLE THE IGNITOR.	

ANNUAL INSPECTION

The furnace should be inspected by a qualified installer, or service agency at least once per year. This check should be performed at the beginning of the heating season. This will ensure that all furnace components are in proper working order and that the heating system functions appropriately. Pay particular attention to the following items. Repair or service as necessary.



- Flue pipe system. Check for blockage and/or leakage. Check the outside termination and the connections at and internal to the furnace.
- Heat exchanger. Check for corrosion and/or buildup within the heat exchanger passageways.
- Burners. Check for proper ignition and flame sense.
- Wiring. Verify that electrical connections are tight and free from corrosion.
- Filters.

AIR FILTER

 WARNING
NEVER OPERATE FURNACE WITHOUT A FILTER AS DUST AND LINT WILL BUILD UP ON INTERNAL PARTS RESULTING IN LOSS OF EFFICIENCY, EQUIPMENT DAMAGE, AND POSSIBLE FIRE.

Filters must be used with this furnace. Filters do not ship with these furnaces but must be provided by the installer for proper furnace operation.

Dirty filters are the most common cause on inadequate heating or cooling performance.

 WARNING	
HIGH VOLTAGE! DISCONNECT ALL POWER BEFORE SERVICING OR INSTALLING THIS UNIT. MULTIPLE POWER SOURCES MAY BE PRESENT. FAILURE TO DO SO MAY CAUSE PROPERTY DAMAGE, PERSONAL INJURY OR DEATH.	

MAINTENANCE

Improper filter maintenance is the most common cause of inadequate heating or cooling performance. Filters should be cleaned (permanent) or replaced (disposable) every two months or as required.

HORIZONTAL UNIT FILTER REMOVAL

Filters in horizontal installations are located in the central return register.

INDUCED DRAFT AND CIRCULATION BLOWERS

The bearings in the induced draft blower and circulator blower motors are permanently lubricated by the manufacturer. No further lubrication is required. Check motor windings for accumulation of dust which may cause overheating. Clean as necessary.

FLAME SENSOR (QUALIFIED SERVICER ONLY)

Under some conditions, the fuel or air supply can create a nearly invisible coating on the flame sensor. This coating acts as an insulator, causing a drop in the flame sensing signal. If this occurs, a qualified servicer must carefully clean the flame sensor with steel wool. After cleaning, the flame sensor output should be as listed on the specification sheet.

The following is a must for every service technician and service shop.

1. Dial type thermometers or thermocouple meter (optional) - to measure dry bulb temperature.
2. Volt-Ohm Meter - to measure amperage and voltage and to test continuity, capacitors and motor windings.
3. Manometer - to measure static pressure, pressure drop across coils, filters and draft and to test gas inlet and manifold pressure.

Other recording type instruments can be essential in solving abnormal problems, however, in many instances they may be rented from local sources.

Proper equipment promotes faster, more efficient service and accurate repairs resulting in fewer call backs.

HEATING PERFORMANCE TEST

Before attempting to diagnose an operating fault code, run a Heating Performance Test to determine if the heating system is performing within 5% of the BTU input found on the rating plate of the unit being tested. To conduct a heating performance test, the BTU input to the unit must be calculated (see Clocking a Gas Meter). Before clocking a gas meter, contact your local utility to provide the caloric value (BTU content) of the natural gas in the area.

It is also important to confirm the airflow (CFM) is within the temperature rise range (see Airflow Data in spec sheet) and external static pressure range (approximately 0.5" water column). How-to instructions can be found in the service manual under Checking External Static Pressure and Checking Temperature Rise.

SCHEDULED MAINTENANCE

CLOCKING A GAS METER

1. Turn off all gas appliances in the home.
2. Turn on the furnace. Ensure the furnace is operating at a 100% firing rate on 2 stage and modulating furnace product.
3. Once heating cycle is at a steady state (typically 15 minutes of operation), use a stopwatch to time how long it takes the smallest unit of measure dial on the gas meter to make a full revolution. In Table 1, one cubic foot is selected. The smallest unit of measure will vary depending on the gas meter.

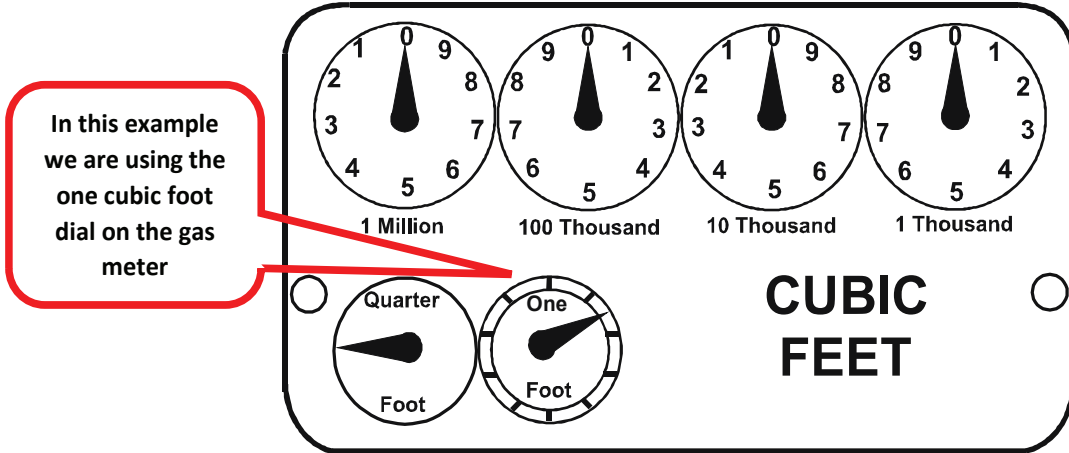

TABLE 1

4. Using Table 2 below, find the number of seconds it took for the dial to make a full revolution. To the right of that number of seconds and below the Size of Test Dial (selected in step 3 and shown in Table 1) will be the Cubic Feet per Hour (CFH).

Locate 40 seconds for one revolution in the chart below

Then locate the 1 cu ft dial column and select the corresponding CFH from the 40 seconds for one revolution row

GAS RATE -- CUBIC FEET PER HOUR											
Seconds for One Revolution	Size of Test Dial					Seconds for One Revolution	Size of Test Dial				
	1/4 cu/ft	1/2 cu/ft	1 cu/ft	2 cu/ft	5 cu/ft		1/4 cu/ft	1/2 cu/ft	1 cu/ft	2 cu/ft	5 cu/ft
10	90	180	360	720	1800	36	25	50	100	200	500
11	82	164	327	655	1636	37	--	--	97	195	486
12	75	150	300	600	1500	38	23	47	95	189	474
13	69	138	277	555	1385	39	--	--	92	185	462
14	64	129	257	514	1286	40	22	45	90	180	450
15	60	120	240	480	1200	41	--	--	--	176	439
16	56	113	225	450	1125	42	21	43	86	172	429
17	53	106	212	424	1059	43	--	--	--	167	419
18	50	100	200	400	1000	44	--	41	82	164	409
19	47	95	189	379	947	45	20	40	80	160	400
20	45	90	180	360	900	46	--	--	78	157	391
21	43	86	171	343	857	47	19	38	76	153	383
22	41	82	164	327	818	48	--	--	75	150	375
23	39	78	157	313	783	49	--	--	--	147	367
24	37	75	150	300	750	50	18	36	72	144	360
25	36	72	144	288	720	51	--	--	--	141	355
26	34	69	138	277	692	52	--	--	69	138	346
27	33	67	133	265	667	53	17	34	--	136	340
28	32	64	129	257	643	54	--	--	67	133	333
29	31	62	124	248	621	55	--	--	--	131	327
30	30	60	120	240	600	56	16	32	64	129	321
31	--	--	116	232	581	57	--	--	--	126	316
32	28	56	113	225	563	58	--	31	62	124	310
33	--	--	109	218	545	59	--	--	--	122	305
34	26	53	106	212	529	60	15	30	60	120	300
35	--	--	103	206	514	--	--	--	--	--	--

TABLE 2

SCHEDULED MAINTENANCE

5. Use this formula to verify the Cubic Feet per Hour (CFH) input determined in step 4 is correct:

$$(3600 \times \text{Gas Meter Dial Size}) / \text{Time (seconds)} = \text{Cubic Feet per Hour (CFH)}$$

3600 is used as there are 60 seconds in a minute and 60 minutes in an hour.
60x60=3600

6. Check with your local utility for actual BTU content (caloric value) of natural gas in the area (the average is 1025 BTU's).
7. Use this formula to calculate the BTU/HR input (See BTU/HR Calculation Example):
Cubic Feet per Hour (CFH) x BTU content of your natural gas = BTU/HR input
8. Should the figure you calculated not fall within five (5) percent of the nameplate rating of the unit, adjust the gas valve pressure regulator or resize orifices. To adjust the pressure regulator on the gas valve, turn downward (clockwise) to increase pressure and input, and upward (counterclockwise) to decrease pressure and input. A properly operating unit must have the BTU per hour input and CFM of air, within the limits shown to prevent short cycling of the equipment. As the external static pressure goes up, the temperature rise will also increase. Consult the proper tables for temperature rise limitation.

BTU/HR Calculation Example:

The unit being tested takes 40 seconds for the 1 cubic foot dial to make one complete revolution. Using the chart, this translates to 90 cubic feet per hour. Based upon the assumption that one cubic foot of natural gas has 1,025 BTU's (Check with your local utility for actual BTU content), the **calculated input is 92,250 BTU's per hour.**

FURNACE NAMEPLATE INPUT IN THIS EXAMPLE: 90,000 BTU/HR

CALCULATED GAS INPUT IN THIS EXAMPLE: 92,250 BTU/HR

This example is within the 5% tolerance input and does not need adjustment.



CAUTION

ALWAYS CONNECT A MANOMETER TO THE OUTLET TAP AT THE GAS VALVE BEFORE ADJUSTING THE PRESSURE REGULATOR. IN NO CASE SHOULD THE FINAL MANIFOLD PRESSURE VARY MORE THAN PLUS OR MINUS .2 INCHES WATER COLUMN FROM 3 INCHES WATER COLUMN FOR NATURAL GAS.

A properly operating unit must have the BTU per hour input and CFM of air, within the limits shown to prevent short cycling of the equipment. As the external static pressure goes up, the temperature rise will also increase. Consult the proper tables for temperature rise limitation.

SERVICING

COMPONENT ID

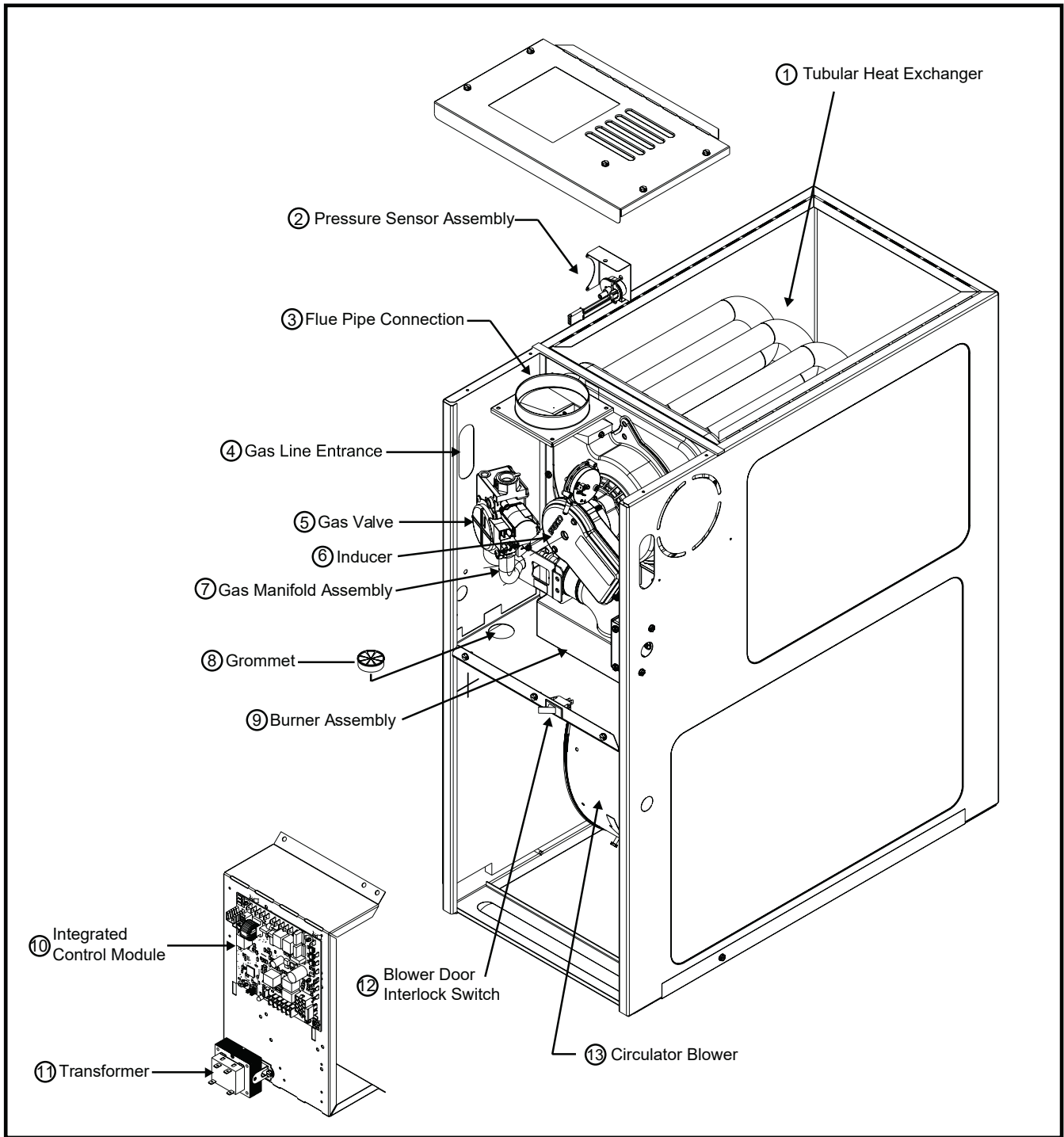

- 1 Tubular Heat Exchanger
- 2 Pressure Switch
- 3 Flue Pipe Connection
- 4 Gas Line Entrance
- 5 Gas Valve
- 6 Inducer
- 7 Gas Manifold Assembly

- 8 Wiring Harness Grommet
- 9 Burner Assembly
- 10 Integrated Control Module
- 11 Transformer
- 12 Blower Door Interlock Switch
- 13 Circulator Blower

SERVICING

CHECKING VOLTAGE



WARNING

HIGH VOLTAGE!
DISCONNECT ALL POWER BEFORE SERVICING OR INSTALLING THIS UNIT. MULTIPLE POWER SOURCES MAY BE PRESENT. FAILURE TO DO SO MAY CAUSE PROPERTY DAMAGE, PERSONAL INJURY OR DEATH.



1. Remove the burner door to gain entry to the Junction Box.
2. Remove cover from the Junction Box and gain access to incoming power lines.

With Power ON:



WARNING

LINE VOLTAGE NOW PRESENT.

3. Using a voltmeter, measure the voltage across the hot and neutral connections.

NOTE: To energize the furnace, the Door Interlock Switch must be engaged at this point.

4. No reading - indicates open wiring, open fuse, no power, or faulty Door Interlock Switch from unit to fused disconnect service. Repair as needed.
5. With ample voltage at line voltage connectors, energize the furnace blower motor by jumpering terminals R to G on the integrated ignition control.
6. With the blower motor in operation, the voltage should be 115 volts \pm 10 percent.
7. If the reading falls below the minimum voltage, check the line wire size. Long runs of undersized wire can cause low voltage. If wire size is adequate, notify the local power company of the condition.
8. After completing check and/or repair, replace Junction Box cover and reinstall the service panel doors.
9. Turn on electrical power and verify proper unit operation.

CHECKING WIRING



WARNING

DISCONNECT ALL POWER BEFORE SERVICING.

1. Check wiring visually for signs of overheating, damaged insulation and loose connections.
2. Use an ohmmeter to check continuity of any suspected open wires.
3. If any wires must be replaced, replace with AWM, 105°C. 2/64 thick insulation of the same gauge or its equivalent.

THERMOSTAT AND WIRING



WARNING

DISCONNECT ALL POWER BEFORE SERVICING.

1. Remove the blower compartment door to gain access to the thermostat low voltage wires located at the furnace integrated control module terminals.
2. Remove the thermostat low voltage wires at the furnace control panel terminal board.
3. Jumper terminals R to W on the integrated ignition control.

With Power On (and Door Interlock Switch closed):



WARNING

LINE VOLTAGE NOW PRESENT.

4. Induced Draft Motor must run and pull in pressure switch.
5. If the hot surface ignitor heats and at the end of the ignitor warm-up period the gas valve opens and the burners ignite, the trouble is in the thermostat or wiring.
6. With power off, check the continuity of the thermostat and wiring. Repair or replace as necessary.

If checking the furnace in the air conditioning mode, proceed as follows.

7. With power off, Jumper terminals R to Y to G.
8. Turn on the power.
9. If the furnace blower motor starts and the condensing unit runs, then the trouble is in the thermostat or wiring. Repair or replace as necessary.
10. After completing check and/or repair of wiring and check and/or replacement of thermostat, reinstall blower compartment door.
11. Turn on electrical power and verify proper unit operation.

CHECKING TRANSFORMER AND CONTROL CIRCUIT

A step-down transformer 120 volt primary to 24 volt secondary, 40 VA (Heating and Cooling Models) supplies ample capacity of power for either operation.



WARNING

HIGH VOLTAGE!
DISCONNECT ALL POWER BEFORE SERVICING OR INSTALLING THIS UNIT. MULTIPLE POWER SOURCES MAY BE PRESENT. FAILURE TO DO SO MAY CAUSE PROPERTY DAMAGE, PERSONAL INJURY OR DEATH.



SERVICING

1. Remove blower compartment door to gain access to the thermostat low voltage wires located at the furnace integrated control module.
2. Remove the thermostat low voltage wires at the furnace integrated control module terminals.

With Power On (and Door Interlock Switch closed):



WARNING

LINE VOLTAGE NOW PRESENT.

3. Use a voltmeter, check voltage across terminals R and C. Must read 24 VAC.
4. No voltage indicates faulty transformer, open fuse, bad wiring, bad splice, or open door interlock switch.
5. Check transformer primary voltage at incoming line voltage connections, fuse, splices, and blower door interlock switch.
6. If line voltage is available to the primary side of transformer and not at secondary side, the transformer is inoperative. Replace.
7. After completing check and/or replacement of transformer and check and/or repair of control circuit, reinstall blower compartment door.
8. Turn on electrical power and verify proper unit operation.

CHECKING AIR CIRCULATOR BLOWER MOTOR



WARNING

DISCONNECT ALL POWER BEFORE SERVICING.

1. Remove blower compartment door to gain access to the circulator blower motor and integrated ignition control.
2. Check for any obstruction that would keep the fan wheel / fan motor from turning.
3. Check wiring, the motor has two wiring harnesses, a main harness and a control harness. The main power harness has: White neutral wire connected to the NEUTRAL terminal on the control board. Black wire connected to the MOTOR terminal on the control board. Red wire connected to the COM terminal, which is a female spade connection next to the HEAT and COOL wires on the control board. Green ground wire connected to cabinet ground. The control power harness has: Blue wire connected to HEAT on the control board. (Medium High Speed) Red wire connected to RED on the control board.

(High Speed) Orange wire connected to FAN on the control board. (Medium Speed) Black (Low Speed) and Brown (Medium Low Speed) wires connected to PARK on the control board. The multi-speed ECM motor requires a line voltage power supply (black connected to MOTOR and white connected to neutral on the control board) as well as a signal on one of the speed taps. The signal to the motor is a 24vAC signal to the speed tap.



WARNING

DISCONNECT ALL POWER BEFORE SERVICING.

CHECKING DUCT STATIC

The maximum and minimum allowable external static pressures are found in the specification section. These tables also show the amount of air being delivered at a given static by a given motor speed or pulley adjustment. The furnace motor cannot deliver proper air quantities (CFM) against statics other than those listed.

Too great of an external static pressure will result in insufficient air that can cause excessive temperature rise, resulting in limit tripping, etc. Whereas not enough static may result in motor overloading.

To determine proper air movement, proceed as follows:

1. With clean filters in the furnace, use a draft gauge (inclined manometer) to measure the static pressure of the return duct at the inlet of the furnace. (Negative Pressure)
2. Measure the static pressure of the supply duct. (Positive Pressure)
3. Add the two (2) readings together for total external static pressure.

NOTE: Both readings may be taken simultaneously and read directly on the manometer if so desired. If an air conditioner coil or Electronic Air Cleaner is used in conjunction with the furnace, the readings must also include these components, as shown in the following drawing.

4. Consult proper tables for the quantity of air.

If the total external static pressure exceeds the minimum or maximum allowable statics, check for closed dampers, registers, undersized and/or oversized poorly laid out duct work.

SERVICING

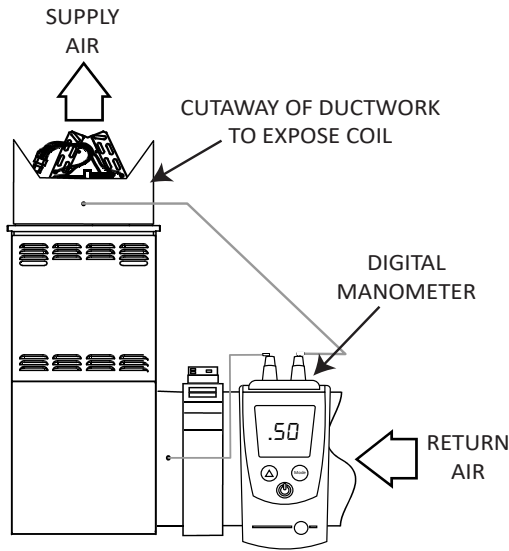

Checking Static Pressure

CHECKING TEMPERATURE RISE

The more air (CFM) being delivered through a given furnace, the less the rise will be; so the less air (CFM) being delivered, the greater the rise. The temperature rise should be adjusted in accordance to a given furnace specifications and its external static pressure. An incorrect temperature rise may result in condensing in or overheating of the heat exchanger. An airflow and temperature rise table is provided in the blower performance specification section. Determine and adjust temperature rise as follows:

1. Operate furnace with burners firing for approximately ten minutes. Check BTU input to furnace - do not exceed input rating stamped on rating plate. Ensure all registers are open and all duct dampers are in their final (fully or partially open) position.
2. Place thermometers in the return and supply ducts as close to the furnace as possible. Thermometers must not be influenced by radiant heat by being able to "see" the heat exchanger.

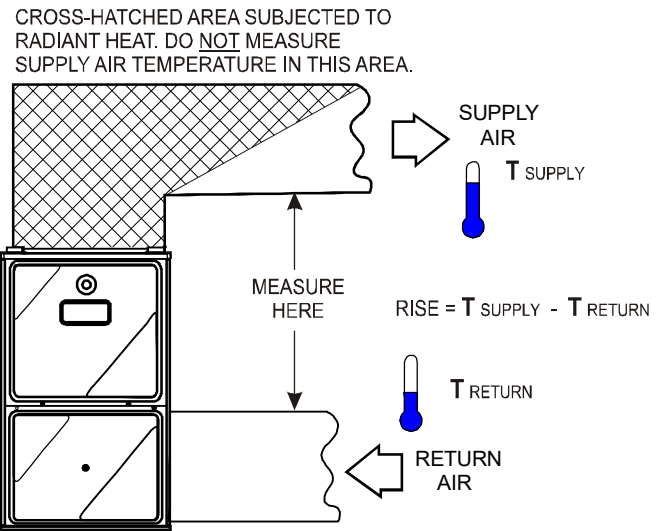

Checking Temperature Rise

3. Subtract the return air temperature from the supply air temperature to determine the air temperature rise. Allow adequate time for thermometer readings to stabilize.
4. Adjust temperature rise by adjusting the circulator blower speed. Increase blower speed to reduce temperature rise. Decrease blower speed to increase temperature rise. Refer to *Circulator Blower Speed* section in the Product Design section of this manual for speed changing details. Temperature rise is related to the BTUH output of the furnace and the amount of air (CFM) circulated over the heat exchanger. Measure motor current draw to determine that the motor is not overloaded during adjustments.

CHECKING PRIMARY LIMIT CONTROL

All use a nonadjustable, automatic reset, bi-metal type limit control.

Style 1 drawing illustrates the Primary Limit used on the 80% furnaces.

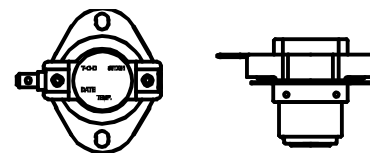

Style 1

SERVICING

WARNING

HIGH VOLTAGE!
DISCONNECT ALL POWER BEFORE SERVICING OR INSTALLING THIS UNIT. MULTIPLE POWER SOURCES MAY BE PRESENT. FAILURE TO DO SO MAY CAUSE PROPERTY DAMAGE, PERSONAL INJURY OR DEATH.



1. Remove burner compartment door to gain access to the primary limit.
2. Remove low voltage wires at limit control terminals.
3. With an ohmmeter, test between these two terminals as shown in the following drawing. The ohmmeter should read continuous unless heat exchanger temperature is above limit control setting. If not as above, replace the control.

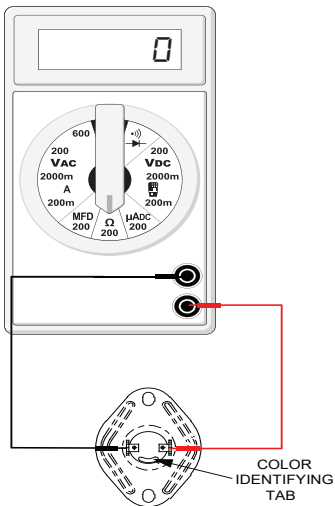

Testing Primary Limit Control

CHECKING AUXILIARY LIMIT CONTROL

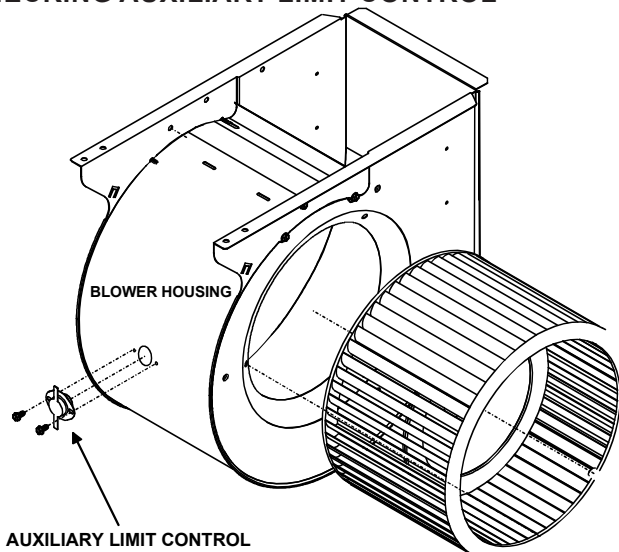

Auxiliary Limit Control Location

WARNING

HIGH VOLTAGE!
DISCONNECT ALL POWER BEFORE SERVICING OR INSTALLING THIS UNIT. MULTIPLE POWER SOURCES MAY BE PRESENT. FAILURE TO DO SO MAY CAUSE PROPERTY DAMAGE, PERSONAL INJURY OR DEATH.

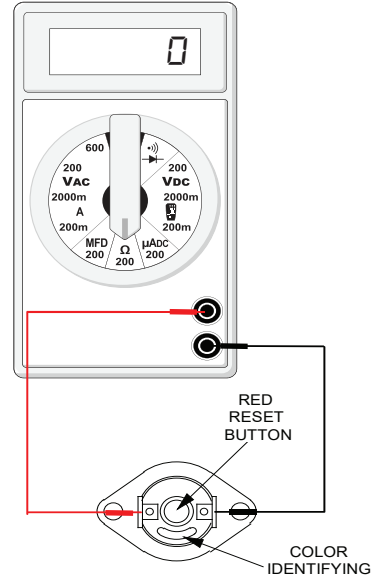

Testing Auxiliary Limit Control

WARNING

TO AVOID POSSIBLE FIRE, ONLY RESET THE AUXILIARY LIMIT CONTROL ONCE. IF IT SHOULD OPEN A SECOND TIME, A QUALIFIED SERVICER MUST DETERMINE WHY THE AUXILIARY LIMIT OPENED BEFORE RESETTING AGAIN.

INDUCED DRAFT BLOWER MOTOR

*MES80*U

WARNING

HIGH VOLTAGE!
DISCONNECT ALL POWER BEFORE SERVICING OR INSTALLING THIS UNIT. MULTIPLE POWER SOURCES MAY BE PRESENT. FAILURE TO DO SO MAY CAUSE PROPERTY DAMAGE, PERSONAL INJURY OR DEATH.



1. Remove burner compartment door to gain access to the induced draft blower motor.
2. Disconnect the motor wire leads from its connection point at the induced draft motor.
3. Using a ohmmeter, test for continuity between each of the motor leads.
4. Touch one probe of the ohmmeter to the motor frame (ground) and the other probe in turn to each lead.

SERVICING

- If the windings do not test continuous or a reading is obtained to ground, replace the motor.
5. If the windings have a continuity reading, reconnect wires. Turn power on to the furnace and turn the thermostat on in the heating mode. Check voltage for 115V at the induced draft motor terminals during the trial for ignition. If you have 115V and the motor does not run, replace the induced draft motor.
 6. After completing check and/or replacement of induced draft motor, reinstall burner compartment door.
 7. Turn on electrical power and verify proper unit operation.

*M9S80*UAA

The induced draft assembly uses a three phase motor to draw flue gases through the heat exchanger. The inducer uses ball bearing and is permanently lubricated. This motor is driven at varying speeds by the VFD (variable frequency drive) section of the IFC. The IFC take typical single phase power supplied to the furnace and converts it to a three phase supply to operate the draft inducer at the desired speed. The windings of the induced draft motor will have equal resistance +/- 5%. Normal resistance readings at room temperature will range from 14-17 ohms. The voltage supplied by the IFC to drive the induced draft blower will vary from 15-110 volts A/C between any two windings. This would be read between any two of the three power wires between the IFC and the induced draft blower. This voltage to the IBD will vary between furnace models and is dependent on what percentage of maximum fire is being called for. The power wires are colored red, white, and black. A green colored ground wire is also present.

CHECKING GAS VALVE (REDUNDANT)

A combination redundant operator type gas valve which provides all manual and automatic control functions required for gas fired heating equipment is used. The valve provides control of main burner gas flow, pressure regulation, and 100 percent safety shut-off.



WARNING

DISCONNECT ALL POWER BEFORE SERVICING.

Single stage gas valves should be tested on the furnace with 24 VAC connected to the gas valve and manometers reading supply line and manifold pressures.



WARNING

DISCONNECT ALL GAS AND ELECTRICAL POWER SUPPLY.

Orifices should be treated with care in order to prevent damage. They should be removed and installed with a box-end wrench in order to prevent distortion. In no instance should an orifice be peened over and redrilled. This will change the angle or deflection of the vacuum effect or entraining of primary air, which will make it difficult to adjust the flame properly. This same problem can occur if an orifice spud of a different length is substituted.



WARNING

DISCONNECT ALL GAS AND ELECTRICAL POWER SUPPLY.

CHECKING GAS PRESSURE

GAS SUPPLY PRESSURE MEASUREMENT



CAUTION

TO PREVENT UNRELIABLE OPERATION OR EQUIPMENT DAMAGE, THE INLET GAS SUPPLY PRESSURE MUST BE AS SPECIFIED ON THE UNIT RATING PLATE WITH ALL OTHER HOUSEHOLD GAS FIRED APPLIANCES OPERATING.

Gas inlet and manifold pressures should be checked and adjusted in accordance to the type of fuel being consumed. The line pressure supplied to the gas valve must be within the range specified below. The supply pressure can be measured at the gas valve inlet pressure tap or at a hose fitting installed in the gas piping drip leg. The supply pressure must be measured with the burners operating. To measure the gas supply pressure, use the following procedure.



WARNING

DISCONNECT ELECTRICAL POWER AND SHUT OFF GAS SUPPLY.

1. After turning off gas to furnace at the manual gas shutoff valve external to the furnace, remove burner compartment door to gain access to the gas valve.
2. Connect a calibrated water manometer (or appropriate gas pressure gauge) at either the gas valve inlet pressure tap or the gas piping drip leg as shown in the following figures. Refer to Measuring Gas Pressure: Single Stage Valves figure for single stage valve inlet pressure tap connections.

NOTE: At either location, a hose fitting must be installed prior to making the hose connection.

NOTE: Use adapter kit #0151K0000S to measure gas pressure on White-Rodgers 36J22 gas valves.

SERVICING

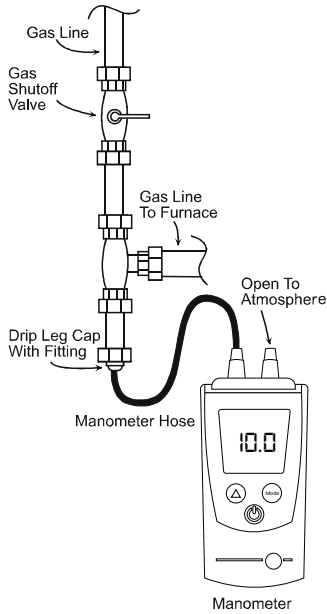

**Measuring Inlet Gas Pressure
(Alternate Method)**

3. Turn ON the gas and electrical power supply and operate the furnace and all other gas consuming appliances on the same gas supply line.
4. Measure furnace gas supply pressure with burners firing. Supply pressure must be within the range specified in the following table.

INLET GAS SUPPLY PRESSURE		
Natural Gas	Minimum: 4.5" w.c.	Maximum: 10.0" w.c.

If supply pressure differs from above, make necessary adjustments to pressure regulator, gas piping size, etc., and/or consult with local gas utility.

WARNING

HIGH VOLTAGE!
DISCONNECT ALL POWER BEFORE SERVICING OR INSTALLING THIS UNIT. MULTIPLE POWER SOURCES MAY BE PRESENT. FAILURE TO DO SO MAY CAUSE PROPERTY DAMAGE, PERSONAL INJURY OR DEATH.



5. Disconnect manometer after turning off gas at manual shutoff valve. Reinstall plug before turning on gas to furnace.
6. Turn OFF any unnecessary gas appliances started in step 3.
7. Turn on gas to furnace and check for leaks. If leaks are found, repair and then reinstall burner compartment door.
8. Turn on electrical power and verify proper unit operation.

GAS MANIFOLD PRESSURE MEASUREMENT AND ADJUSTMENT

CAUTION

TO PREVENT UNRELIABLE OPERATION OR EQUIPMENT DAMAGE, THE GAS MANIFOLD PRESSURE MUST BE AS SPECIFIED ON THE UNIT RATING PLATE. ONLY MINOR ADJUSTMENTS SHOULD BE MADE BY ADJUSTING THE GAS VALVE PRESSURE REGULATOR.

NOTE: Use adapter kit #0151K0000S to measure gas pressure on White-Rodgers 36J22 gas valves.

Only small variations in gas pressure should be made by adjusting the gas valve pressure regulator. The manifold pressure must be measured with the burners operating. To measure and adjust the manifold pressure, use the following procedure.

WARNING

HIGH VOLTAGE
DISCONNECT ALL ELECTRICAL POWER AND SHUT OFF GAS SUPPLY BEFORE SERVICING OR INSTALLING.

1. After turning off gas to furnace at the manual gas shutoff valve external to the furnace, remove burner compartment door to gain access to the gas valve.
2. Connect a calibrated water manometer (or appropriate gas pressure gauge) at the gas valve outlet pressure tap. Refer to *Measuring Gas Pressure: Single Stage Valves* figure for single stage valve outlet pressure tap connections.

WARNING

LINE VOLTAGE NOW PRESENT.

3. Turn ON the gas and electrical power supply and operate the furnace.
4. Measure gas manifold pressure with burners firing. Adjust manifold pressure using the table below.

Manifold Gas Pressure

Natural Gas	2.8 -3.2" w.c.
-------------	----------------

The final manifold pressure must not vary from the above specified pressures. Any necessary major changes in gas flow rate should be made by changing the size of the burner orifice.

SERVICING

5. White-Rodgers 36G22 Valves:
 - a. Back outlet pressure test screw (inlet/outlet pressure boss) out one turn (counterclockwise, not more than one turn).
 - b. Attach a hose and manometer to the outlet pressure outlet pressure boss.
 - c. Turn ON the gas supply.
 - d. Turn on power and close thermostat "R" and "W" contacts to provide a call for low stage heat.
 - e. Measure the gas manifold pressure with burners firing. Adjust manifold pressure using the *Manifold Gas Pressure* table shown below.
 - f. Remove regulator cover screw from the outlet pressure regulator adjust tower and turn screw clockwise to increase pressure or counterclockwise to decrease pressure. Replace regulator cover screw.
 - g. Turn off all electrical power and gas supply to the system.
 - h. Remove the manometer hose from the hose barb fitting or outlet pressure boss.
 - i. Turn outlet pressure test screw in to seal pressure port (clockwise, 7 in-lb minimum).

 WARNING
HIGH VOLTAGE DISCONNECT ALL ELECTRICAL POWER AND SHUT OFF GAS SUPPLY BEFORE SERVICING OR INSTALLING.

 WARNING
DISCONNECT ALL POWER BEFORE SERVICING.

CHECKING HOT SURFACE IGNITER

120V Silicon Nitride Igniter - ULN furnaces use a 120V silicon nitride igniter, part #0130F00717. The normal operating temperature is approximately 2156°F - 2678°F. At room temperature the igniter ohm reading should be from 20-100 ohms.

 WARNING
LINE VOLTAGE NOW PRESENT.

CHECKING PRESSURE TRANSDUCER (80% ULN)

The 80% ULN products utilize a pressure transducer (in lieu of a pressure switch). The pressure transducer signals the control board to modulate the heating cycle during a call for heat by regulating the induced draft motor speed. By regulating the speed of the induced draft motor, proper air-fuel ratios are maintained.



Sensing range specification: 0.0-4.0 inches W.C.

Voltage specifications:

- Steady State: 5.0 vDC from red to green wire (transducer wiring harness input).
- With Inducer off: 0.5 vDC from black to green wire (transducer wiring harness output).
- During operation: Output range equals 0.5 - 4.5 vDC.

Potential errors:

1. Control board does not receive 0.25 vDC for inducer motor with motor off.
 - a. Will result in 2-flash error code on the control board.
2. Control board does not receive the required voltage change (0.5 - 4.5 vDC) during inducer motor operation.
 - a. Will result in 3-flash error code on the control board.

 WARNING
HIGH VOLTAGE! DISCONNECT ALL POWER BEFORE SERVICING OR INSTALLING THIS UNIT. MULTIPLE POWER SOURCES MAY BE PRESENT. FAILURE TO DO SO MAY CAUSE PROPERTY DAMAGE, PERSONAL INJURY OR DEATH.

6. Turn on gas to furnace and check for leaks. If leaks are found, repair and then reinstall burner compartment door.
7. Turn on electrical power and verify proper unit operation.

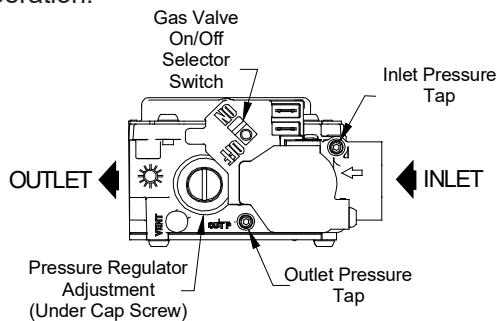

SERVICING



WARNING

HIGH VOLTAGE!

DISCONNECT ALL POWER BEFORE SERVICING OR INSTALLING THIS UNIT. MULTIPLE POWER SOURCES MAY BE PRESENT. FAILURE TO DO SO MAY CAUSE PROPERTY DAMAGE, PERSONAL INJURY OR DEATH.



CHECKING FOR DELAYED IGNITION

Delayed ignition is a delay in lighting a combustible mixture of gas and air which has accumulated in the combustion chamber.

Furnace design makes this extremely unlikely unless safety controls have been by-passed or tampered with. Never by-pass or alter furnace controls.

If delayed ignition should occur, the following should be checked:

1. Improper gas pressure - adjust to proper pressure (See *CHECKING GAS PRESSURE*).

FIELD TEST MODE

Function: When the SW1 button is pressed and held until the LED is blinking in AMBER (more than 10 seconds, less than 15 seconds), the control will execute a field test mode sequence to cycle through component operation.

Operation: The control must be powered and the thermostat satisfied (no call for heat or cool). Depress and hold the SW1 button for at least 10 seconds (but not more than 15 seconds), until the LED is blinking in AMBER, then release. The control will execute the following functions:

1. Blower - "Heat" Speed 15 seconds
2. Blower - "Cool" Speed 15 seconds
3. Blower - "Fan" Speed 15 seconds
4. Hot Surface Igniter 17 seconds
5. Inducer - "Run" setting 15 seconds
6. Inducer - 2.0" w.c. 60 seconds
7. Return to OFF mode

Once the Field Test Mode is initiated, all thermostat inputs will be ignored until the field test sequence is completed. If the SW1 button is held for more than 15 seconds, the button press will be ignored and the LED display will return to its prior state.

CHECKING INTEGRATED IGNITION CONTROL BOARDS

NOTE: Failure to earth ground the furnace, reversing the neutral and hot wire connection to the line (polarity), or a high resistance connection in the neutral line may cause the control to lockout due to failure to sense flame.



WARNING

TO AVOID THE RISK OF ELECTRICAL SHOCK, WIRING TO THE UNIT MUST BE PROPERLY POLARIZED AND GROUNDED. DISCONNECT POWER BEFORE PERFORMING SERVICE LISTED BELOW.

The ground wire must run from the furnace all the way back to the electrical panel. Proper grounding can be confirmed by disconnecting the electrical power and measuring resistance between the neutral (white) connection and the burner closest to the flame sensor. Resistance should be less than 10 ohms.

The ignition control is a combination electronic and electromechanical device and is not field repairable. Complete unit must be replaced.



WARNING

LINE VOLTAGE NOW PRESENT.

These tests must be completed within a given time frame due to the operation of the ignition control.

NOTE: The *MES80*UAA models use PCBF161 with ID Plug.

1. Check for 120 volts from Line 1 (Hot) to Line 2 (Neutral) at the ignition control. No voltage, check the door switch connections and wire harness for continuity.
2. Check for 24 volts from W to C terminal on the ignition control. No voltage. Check transformer, room thermostat, and wiring.
If you have 24 volts coming off the transformer but receive approximately 13 volts on the terminal board between (C) and (R), check for blown fuse.
3. Check for 120 volts to the induced draft blower by measuring voltage between Pin 4 & 5 (black & white wire on 5 pin connector.)
4. If voltage is present in Steps 1 through 3 and the induced draft blower is operating, check for 120 volts to the ignitor during the preheat cycle.
5. After the ignitor warmup time, begin checking for 24 volts to the gas valve. Voltage will be present for seven seconds only if proof of flame has been established.

NOTE: For *M9S80*UAA models, refer to the Induced Draft Blower Motor information on page 24 to complete step 3 above.

SERVICING

CHECKING FLAME SENSOR



WARNING

HIGH VOLTAGE!

DISCONNECT ALL POWER BEFORE SERVICING OR INSTALLING THIS UNIT. MULTIPLE POWER SOURCES MAY BE PRESENT. FAILURE TO DO SO MAY CAUSE PROPERTY DAMAGE, PERSONAL INJURY OR DEATH.



1. Disconnect the yellow flame sensor wire from the sensor
2. Connect a micro-amp meter in series with this wire and the sensor terminal.
3. Place the unit into a heating cycle.



WARNING





LINE VOLTAGE NOW PRESENT.

4. As soon as flame is established a micro-amp reading should be evident once proof of flame (micro-amp reading) is established, the hot surface ignitor will be de-energized.
5. The Integrated Ignition controls will have 3-10 uAmps. 1-3 uAmps is considered low and will flash 1 amber light. Anything below 1 uAmps and the unit will shut down. If the micro-amp reading is less than the minimum specified, check for high resistance wiring connections, sensor to burner gap, dirty flame sensor, or poor grounding.
6. If absolutely no reading, check for continuity on all components and if good - replace ignition control module.

NOTE: Contaminated fuel or combustion air can create a nearly invisible coating on the flame sensor. This coating works as an insulator causing a loss in the flame sense signal. If this situation occurs the flame sensor must be cleaned with steel wool.













TROUBLESHOOTING

MES80*U

Furnace Status	LED Code ¹	Fault Description(s)	Possible Causes	Corrective Action	Cautions & Notes
<ul style="list-style-type: none"> Furnace fails to operate. Control LED is off. 	<ul style="list-style-type: none"> None 	<ul style="list-style-type: none"> No 120-volt power to furnace or 24-volt power to integrated control module. Integrated control has an internal fault. 	<ul style="list-style-type: none"> Manual disconnect switch OFF, door switch open, or 24-volt wires improperly connected or loose. Bad integrated control module. 	<ul style="list-style-type: none"> Assure 120- and 24-volt power to furnace integrated control module. Check for possible shorts in 120- and 24-volt circuits. Repair as necessary. Replace bad control module. 	<ul style="list-style-type: none"> Turn power OFF prior to repair. Read precautions in "Electrostatic Discharge" section of manual.
<ul style="list-style-type: none"> Furnace fails to operate. Control LED is flashing ONE (1) RED flash. 	 1 Flash RED	<ul style="list-style-type: none"> Furnace lockout due to an excessive number of ignition attempts. (3 total retries)² 	<ul style="list-style-type: none"> Failure to establish flame maybe due to no gas to burner, bad igniter or igniter alignment, improper orifices, or coated/oxidized or improperly connected or shorted flame sensor. Loss of flame after establishment maybe due to interrupted gas supply, lazy burner flames (improper gas pressure or restriction in flue or improper induced draft blower performance). Improperly connected igniter or bad igniter or ground connection to unit or burner. Faulty integrated control. 	<ul style="list-style-type: none"> Locate and correct gas interruption. Replace bad gas valve or gas orifice size. Check flame sense signal. Clean sensor if coated and/or oxidized. Replace induced draft blower pressure sensor. Inspect pressure sensor hose. Repair, if necessary. Inspect flue or condensate for blockage, proper length, elbows, and termination. Compare igniter resistance to specification. Replace igniter if necessary. Check and correct unit ground wiring. Replace bad control module. 	<ul style="list-style-type: none"> Turn power and gas OFF prior to repair. Igniter is fragile, handle with care. Clean flame sensor with steel wool. Replace igniter with proper replacement part. Read precautions in "Electrostatic Discharge" section of manual.
<ul style="list-style-type: none"> Furnace Fails to operate Control LED is flashing TWO (2) RED flashes. 	 2 Flashes RED	<ul style="list-style-type: none"> Pressure sensor indicates pressure reading when it should be zero. 	<ul style="list-style-type: none"> Faulty wiring to the pressure sensor. Faulty pressure sensor. 	<ul style="list-style-type: none"> Check and correct pressure sensor wiring. Replace pressure sensor. 	<ul style="list-style-type: none"> Turn power OFF prior to repair. Replace pressure sensor with proper replacement part.
<ul style="list-style-type: none"> Induced draft blower runs continuously with no further furnace operation. Control LED is flashing THREE (3) RED flashes. 	 3 Flashes RED	<ul style="list-style-type: none"> Inducer not making pressure setting. Induced draft blower is operating properly. 	<ul style="list-style-type: none"> Pressure sensor hoses blocked, pinched or connected improperly. Bad wire connection. Blocked intake, flue or weak induced draft blower. 	<ul style="list-style-type: none"> Replace induced draft blower pressure sensor and hoses. Replace with proper parts. Check wiring connections. Inspect intake and flue for blockage, proper length, elbows, and termination. Replace induced draft blower. 	<ul style="list-style-type: none"> Turn power OFF prior to repair. See "Combustion and Ventilation Air Requirements" and "Category I Venting (Vertical Venting)" section for details.
<ul style="list-style-type: none"> Circulator blower runs continuously. No furnace operation. Control LED is flashing FOUR (4) RED flashes. 	 4 Flashes RED	<ul style="list-style-type: none"> Primary limit insert; or aux limit circuit is open. 	<ul style="list-style-type: none"> Insufficient conditioned air over the heat exchanger. Blocked filters, restrictive ductwork, improper circulator blower speed, or failed circulator blower. Faulty primary limit insert; or aux limit switch. Loose or improperly connected wiring. 	<ul style="list-style-type: none"> Check circulator blower speed and performance. Correct speed or replace blower if necessary. Check filters and ductwork for blockage. Clean filters or remove obstruction. Check primary limit. Check position of heat exchanger shield. Check wiring connections. 	<ul style="list-style-type: none"> Turn power OFF prior to repair. Replace blower with correct replacement part. Replace primary switch insert; or aux limit with proper replacement part.
<ul style="list-style-type: none"> Induced draft blower and circulator blower runs continuously. No furnace operation. Control LED is flashing FIVE (5) RED flashes. 	 5 Flashes RED	<ul style="list-style-type: none"> Flame sensed with no call for heat. 	<ul style="list-style-type: none"> Faulty integrated control module. 	<ul style="list-style-type: none"> Replace bad integrated control module. 	<ul style="list-style-type: none"> Turn power OFF prior to repair.



TROUBLESHOOTING

MES80*U

Furnace Status	LED Code ¹	Fault Description(s)	Possible Causes	Corrective Action	Cautions & Notes
<ul style="list-style-type: none"> Furnace fails to operate. Control LED is flashing SIX (6) RED flashes. 		<ul style="list-style-type: none"> Burner temperature limit switch open. 	<ul style="list-style-type: none"> Excessive flame. Blocked flue and/or air inlet pipe, or a failed induced draft blower. Loose or improperly connected wiring. Faulty burner temperature switch. 	<ul style="list-style-type: none"> Check and correct gas supply pressure. Replace bad gas valve or gas orifice size. Check flue and air inlet piping for blockage, proper length, elbows, and termination. Check induced draft blower for proper performance. Replace, if necessary. Check burner temperature switch. Replace if necessary. Check wiring connections. 	<ul style="list-style-type: none"> See "Vent/Flue Pipe" section for piping details. Replace induced draft blower with proper replacement part. Replace burner temperature switch with correct replacement part.
<ul style="list-style-type: none"> No furnace operation. Control LED is flashing SEVEN (7) RED flashes. 		<ul style="list-style-type: none"> Gas valve circuit shorted. 	<ul style="list-style-type: none"> Bad wiring Faulty integrated control module. 	<ul style="list-style-type: none"> Inspect and replace wiring as needed. Replace bad integrated control module. 	<ul style="list-style-type: none"> Turn power OFF prior to repair. Read precautions in "Electrostatic Discharge" section of manual.
<ul style="list-style-type: none"> No furnace operation. Control LED is flashing EIGHT (8) RED flashes. 		<ul style="list-style-type: none"> Excessive inducer motor speed or drive signal is required. 	<ul style="list-style-type: none"> Vent blockage or inducer hindrance. Faulty wiring to the pressure sensor. 	<ul style="list-style-type: none"> Inspect vent and inducer for blockage or excessive wear and replace as needed. Check and correct pressure sensor wiring. 	<ul style="list-style-type: none"> Turn power OFF prior to repair. Replace induced draft blower with proper replacement part.
<ul style="list-style-type: none"> LED is steady on 		<ul style="list-style-type: none"> OEM test mode 	<ul style="list-style-type: none"> N/A 		
<ul style="list-style-type: none"> Control LED is flashing ONE (1) AMBER flash. 		<ul style="list-style-type: none"> Low flame sense 	<ul style="list-style-type: none"> Flame sensor incorrectly positioned in burner flame. Flame sensor is coated/oxidized. Lazy burner flame due to improper gas pressure or combustion air. 	<ul style="list-style-type: none"> Inspect for proper sensor alignment. Clean flame rod. Compare current gas pressure to rating plate info. Adjust as needed. 	<ul style="list-style-type: none"> Turn power OFF prior to repair. Clean flame sensor with steel wool. See rating plate for proper gas pressure.
<ul style="list-style-type: none"> Control LED is flashing TWO (2) AMBER flashes. 		<ul style="list-style-type: none"> ID plug failure 	<ul style="list-style-type: none"> Improper ID plug. 	<ul style="list-style-type: none"> Replace ID plug. 	<ul style="list-style-type: none"> Turn power OFF prior to repair.
<ul style="list-style-type: none"> Control LED is flashing THREE (3) AMBER flashes. 		<ul style="list-style-type: none"> Integrated control module fuse is blown. 	<ul style="list-style-type: none"> Blown fuse. 	<ul style="list-style-type: none"> Replace integrated control module fuse (3A). 	<ul style="list-style-type: none"> Turn power OFF prior to repair.
<ul style="list-style-type: none"> LED is steady on 		<ul style="list-style-type: none"> Normal operation, idle/standby. 	<ul style="list-style-type: none"> N/A 		
<ul style="list-style-type: none"> Integrated control module LED is flashing rapidly. 		<ul style="list-style-type: none"> Clear error history. 	<ul style="list-style-type: none"> N/A 	<ul style="list-style-type: none"> Press and hold the SW1 button for more than 5 secs results in the display of this mode. 	<ul style="list-style-type: none"> Release the button while LED is flashing GREEN to clear error history.
<ul style="list-style-type: none"> Integrated control module LED is flashing ONE (1) GREEN flash. 		<ul style="list-style-type: none"> Call for heating. 	<ul style="list-style-type: none"> N/A 		
<ul style="list-style-type: none"> Integrated control module LED is flashing TWO (2) GREEN flashes. 		<ul style="list-style-type: none"> Call for cooling. 	<ul style="list-style-type: none"> N/A 		
<ul style="list-style-type: none"> Integrated control module LED has THREE (3) GREEN rapid flashes. 		<ul style="list-style-type: none"> Continuous fan operation. 	<ul style="list-style-type: none"> N/A 		

TROUBLESHOOTING

MES80*U

<ul style="list-style-type: none"> • Integrated control module LED has THREE (3) GREEN rapid flashes. 	 <p>3 Rapid Flashes GREEN</p>	<ul style="list-style-type: none"> • ID plug installed 	<ul style="list-style-type: none"> • N/A 	<ul style="list-style-type: none"> • For control with unit-specific programming imbedded in the CPU, this indicates at power-up that a valid ID plug has been installed and the control will use the alternate parameters. 	
<ul style="list-style-type: none"> • Abnormal high pitch noise during burner operation. 	 <p>1 Flash GREEN</p>	<ul style="list-style-type: none"> • Abnormal combustion noise during heating. 	<ul style="list-style-type: none"> • Insufficient combustion air or high input. • Blocked flue and/or air inlet pipe, or faulty induced draft blower or pressure sensor. 	<ul style="list-style-type: none"> • Check and correct gas supply and manifold pressures. • Replace bad gas valve or gas orifice size. • Check flue and air inlet piping for blockage, proper length, elbows, and termination. • Check induced draft blower and pressure sensor for proper performance. 	<ul style="list-style-type: none"> • Turn power and gas OFF prior to repair. • See "Vent/Flue Pipe" section for piping details. • Replace induced draft blower or pressure sensor with proper replacement part.

FAULT CODE RECALL

Function: When the SW1 button is pressed momentarily, the control displays the last five (5) fault codes recorded in non-volatile memory upon demand.

Operation: Any time the control is powered, the fault code history can be retrieved for display by depressing and releasing the SW1 button once (less than 5 seconds); the LED will flash the Fault Code History (up to 5 fault codes from newest to oldest.)

FAULT CODE CLEAR

Function: When the SW1 button is pressed and held for an extended period (more than 5 seconds, less than 10 seconds), the control erases the stored fault code history.

Operation: Any time the control is powered, the fault code history can be cleared by depressing and holding the SW1 button for at least 5 seconds (but not more than 10 seconds) until the LED is blinking GREEN, and then release the switch while the LED is still blinking GREEN. The fault code history will be erased.

TROUBLESHOOTING

***M9S80*U**

Symptom	LED Status	Fault Description	Corrective Actions
Normal Operation	! dL	Stand-by Mode Normal Operation	None
Furnace fails to operate	EEE	Internal Control Fault	Replace control board
Furnace fails to operate	EE0	Furnace lockout due to an excessive number of ignition "retries" (3 total) Failure to establish flame Loss of flame after establishment	Locate and correct gas interruption Replace or realign igniter Check flame sense signal, clean sensor if coated or oxidized Check flue piping for blockage, proper length, elbows, and termination Verify proper induced draft blower performance
Furnace fails to operate	EE1	Draft Inducer pressure switch circuit is closed at start of heating cycle Draft Inducer pressure switch contacts sticking Short in pressure switch circuit wiring	Replace Draft Inducer pressure switch Repair short in wiring
Induced draft blower runs continuously with no operation	EE2	Draft Inducer pressure switch circuit is not closed Pressure switch hose blocked/pinched, or connected improperly Blocked flue and/or inlet air or weak induced draft blower Incorrect pressure switch set point or malfunctioning switch contacts Loose or improperly connected wiring in high limit circuit	Inspect pressure switch hose, repair/replace if necessary Inspect flue and/or inlet air for blockage, proper length, elbows, and termination Check induced draft blower performance, correct as necessary Check pressure switch operation, replace as needed Tighten or correct wiring connection
Circulator blower runs continuously No furnace operation	EE3	Primary limit circuit is open Insufficient conditioned air over the heat exchanger Blocked filters, restrictive ductwork, improper circulator blower speed, or failed circulator blower motor Loose or improperly connected wiring in high limit circuit	Check filters and ductwork for blockage Clean filters or remove obstruction Check circulator blower speed and performance Correct speed or replace blower motor if necessary Tighten or correct wiring connection
Induced draft blower and circulator blower runs continuously No furnace operation	EE4	Flame sensed with no call for heat Short to ground in flame sense circuit Lingering burner flame Slow closing gas valve	Correct short at flame sensor or in flame sensor wiring Check for lingering or lazy flame Verify proper operation of gas valve
No furnace operation	EE5	Open fuse Short in low voltage wiring	Replace fuse Locate and correct short in low voltage wiring
Furnace operates but shows weak flame signal fault	EE6	Flame sense micro amp signal is minimal Flame sensor is coated/oxidized Flame sensor incorrectly positioned in burner flame Lazy burner flame due to improper gas pressure or combustion air	Clean flame sensor if coated or oxidized Inspect for proper flame sensor alignment Check inlet air for blockage Compare current gas pressure to rating plate and adjust as needed
Furnace fails to operate	EE7	Problem with igniter circuit Improperly connected or shorted igniter Poor unit ground Igniter relay fault on integrated control module	Check and correct wiring from integrated control module to igniter Diagnose and replace shorted igniter as needed Verify and correct unit ground wiring if needed Check igniter output from control, replace if necessary

TROUBLESHOOTING

***M9S80*U**

Symptom	LED Status	Fault Description	Corrective Actions
Furnace fails to operate	EEA	Polarity of 115 volt AC is reversed	Correct polarity, check and correct wiring if necessary
		Poor unit ground	Verify proper ground, correct if necessary
Furnace fails to operate	EEb	Gas valve is energized when it should not be	Check wiring in gas valve circuit
		Internal gas valve error	Replace integrated control board
Furnace fails to operate	EEc	Gas valve is not energized when it should be	Check wiring in gas valve circuit
		External Gas Valve Error	Replace integrated control board
Furnace fails to operate	EEd	Auxiliary limit switch (blower compartment) circuit is open	Furnace power was turned off during heat cycle
			Blower not operating during heat
Furnace fails to operate	EId	Grounding Error	Faulty aux limit or wiring
			Check grounding
Furnace fails to operate	EIf	Burner limit switch circuit is open	Check and correct gas supply pressure
			Check flue and air inlet for blockage, proper length, elbows, and termination
			Check wiring connection in limit circuit
			Check burner temperature switch, replace if necessary
Furnace fails to operate	EId	Redundant relay open alarm	Replace integrated control board
Furnace fails to operate	EIf	Redundant relay stuck closed alarm	Replace integrated control board
Furnace fails to operate	EbF	Inducer communication alarm	Check Red, Black, White harness & connections to inducer & control board
Furnace fails to operate	Eib	APS reference error	Check Red, Black, Green harness & connections to pressure sensor & control board
			Replace pressure sensor
Furnace fails to operate	EiC	APS null error	Check Red, Black, Green harness & connections to pressure sensor & control board
			Check pressure hoses to pressure sensor and pressure switch
Furnace fails to operate	EId	APS span error	Check Red, Black, Green harness & connections to pressure sensor & control board
			Check pressure hoses to pressure sensor and pressure switch
Furnace fails to operate	EIE	APS pressure error	Check Red, Black, Green harness & connections to pressure sensor & control board
			Replace pressure sensor
Furnace fails to operate	EIf	APS input error	Check Red, Black, Green harness & connections to pressure sensor & control board
			Replace pressure sensor
	EEH	Twining error	
Furnace fails to operate	EbL	Low circulator current	Check motor 120V line wire is connected to terminal inside current transformer loop
			Check wire connections to motor and PCB
Furnace fails to operate	EbU	Circulator current unexpected	Check motor 120V line wire is connected to terminal inside current transformer loop
Furnace fails to operate	EId	No shared data	Populate shared data set using memory card

WIRING DIAGRAMS

*MES80*U* (WITH PCBBF161 CONTROL BOARD)

WARNING
 HIGH VOLTAGE!
 DISCONNECT ALL POWER BEFORE SERVICING OR INSTALLING THIS UNIT. MULTIPLE POWER SOURCES MAY BE PRESENT. FAILURE TO DO SO MAY CAUSE PROPERTY DAMAGE, PERSONAL INJURY OR DEATH.

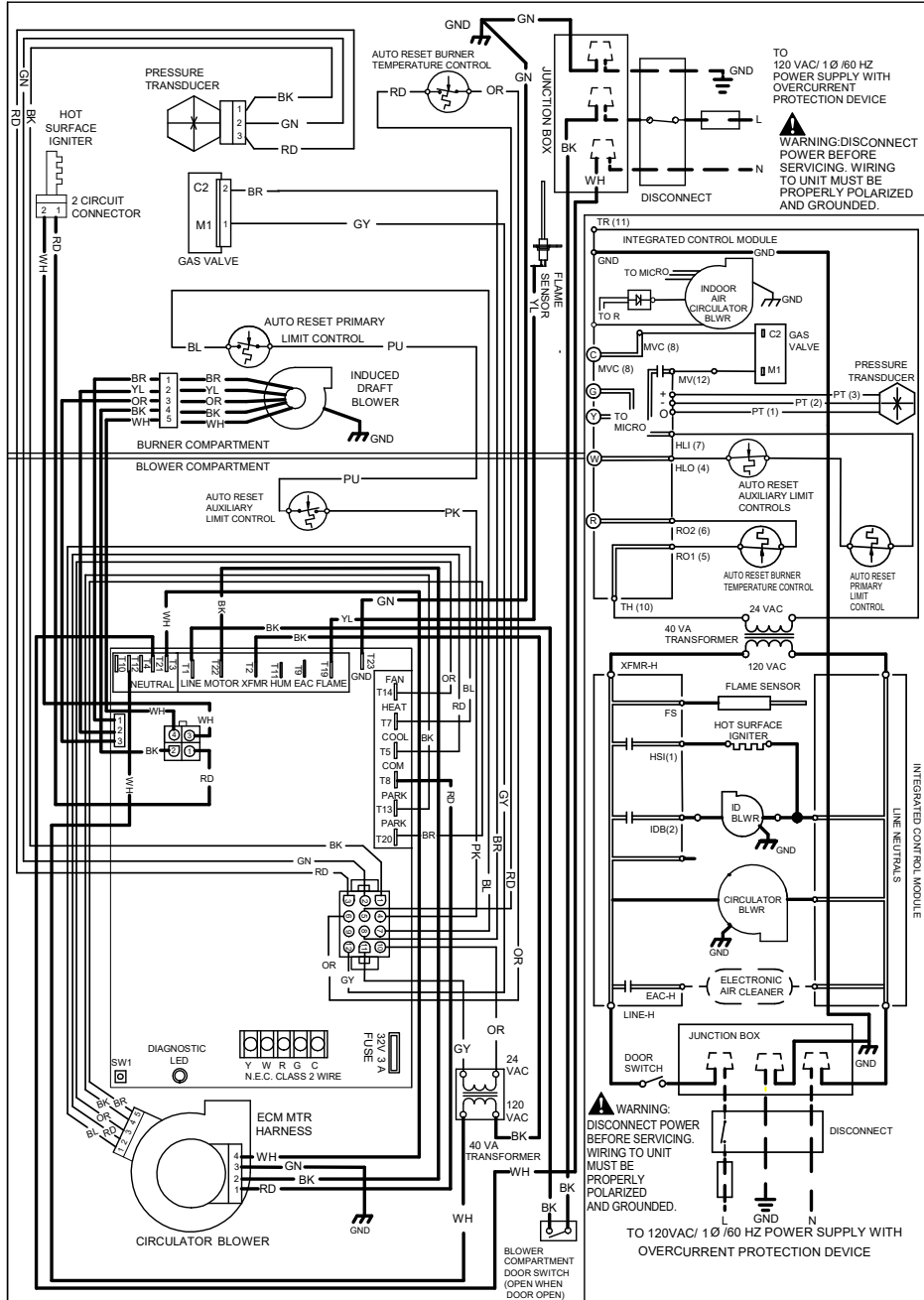

LED ACTIVITY	RED	AMBER	GREEN	NOTES
STEADY ON	CONTROL FAULT DETECTED HARD LOCKOUT	OEM TEST MODE	STANDBY NORMAL OPERATION NO THERMOSTAT REQUESTS	1. SET HEAT ANTICIPATOR ON ROOM THERMOSTAT AT 0.7 AMPS.
RAPID FLASH	REVERSED LINE VOLTAGE POLARITY	FIELD TEST MODE	CLEAR ERROR HISTORY	2. MANUFACTURER'S SPECIFIED REPLACEMENT PARTS MUST BE USED WHEN SERVICING.
1 FLASH	SYSTEM LOCKOUT - RETRIES EXCEEDED	LOW FLAME SENSE	CALL FOR HEATING	3. IF ANY OF THE ORIGINAL WIRE AS SUPPLIED WITH THE FURNACE MUST BE REPLACED, IT MUST BE REPLACED WITH WIRING MATERIAL HAVING A TEMPERATURE RATING OF AT LEAST 105° C. USE COPPER CONDUCTORS ONLY.
2 FLASHES	PS NULL ERROR - INCONSISTENT READING WITH INDUCER OFF	ID PLUG FAILURE	CALL FOR COOLING	4. BLOWER SPEEDS SHOULD BE ADJUSTED BY INSTALLER TO MATCH THE INSTALLATION REQUIREMENTS SO AS TO PROVIDE THE CORRECT HEATING TEMPERATURE RISE AND THE CORRECT COOLING CFM.
3 FLASHES	PS NULL ERROR - INCONSISTENT READING WITH INDUCER ON	CONTROL FUSE OPEN	CONTINUOUS FAN OPERATION	5. UNIT MUST BE PERMANENTLY GROUNDED AND CONFORM TO N.E.C. AND LOCAL CODES.
4 FLASHES	HIGH LIMIT SWITCH OPEN	---	---	
5 FLASHES	FLAME PRESENT WITH GAS VALVE OFF	---	---	
6 FLASHES	AUXILIARY LIMIT OPEN	---	---	
7 FLASHES	GAS VALVE CIRCUIT SHORTED	---	---	
8 FLASHES	BLOCKED VENT	---	---	
OFF NO LED ACTIVITY	NO 24 VAC POWER TO CONTROL			
FAULT CODE HISTORY CAN BE RETRIEVED FOR DISPLAY BY DEPRESSING AND RELEASING THE SW1 BUTTON ONCE				

- NOTES:**
- SET HEAT ANTICIPATOR ON ROOM THERMOSTAT AT 0.7 AMPS.
 - MANUFACTURER'S SPECIFIED REPLACEMENT PARTS MUST BE USED WHEN SERVICING.
 - IF ANY OF THE ORIGINAL WIRE AS SUPPLIED WITH THE FURNACE MUST BE REPLACED, IT MUST BE REPLACED WITH WIRING MATERIAL HAVING A TEMPERATURE RATING OF AT LEAST 105° C. USE COPPER CONDUCTORS ONLY.
 - BLOWER SPEEDS SHOULD BE ADJUSTED BY INSTALLER TO MATCH THE INSTALLATION REQUIREMENTS SO AS TO PROVIDE THE CORRECT HEATING TEMPERATURE RISE AND THE CORRECT COOLING CFM.
 - UNIT MUST BE PERMANENTLY GROUNDED AND CONFORM TO N.E.C. AND LOCAL CODES.
- LOW VOLTAGE (24V) ———
 LOW VOLTAGE FIELD ———
 HI VOLTAGE (120V) ———
 HI VOLTAGE FIELD ———
- JUNCTION TERMINAL —●—
 OUTPUT —○—
 INTERNAL TO INTEGRATED CONTROL —□—
 PLUG CONNECTION —□—

EQUIPMENT GND
 FIELD GND
 FIELD SPlice
 SWITCH (TEMP.)
 IGNITER
 SWITCH (PRESS.)
 OVERCURRENT PROT. DEVICE

COLOR CODES: PK PINK
 YL YELLOW BR BROWN
 OR ORANGE WH WHITE
 PU PURPLE BL BLUE
 GN GREEN GY GRAY
 BK BLACK RD RED

0140F02478-A

Wiring is subject to change. Always refer to the wiring diagram on the unit for the most up-to-date wiring.

WARNING
 HIGH VOLTAGE!
 DISCONNECT ALL POWER BEFORE SERVICING OR INSTALLING THIS UNIT. MULTIPLE POWER SOURCES MAY BE PRESENT. FAILURE TO DO SO MAY CAUSE PROPERTY DAMAGE, PERSONAL INJURY OR DEATH.

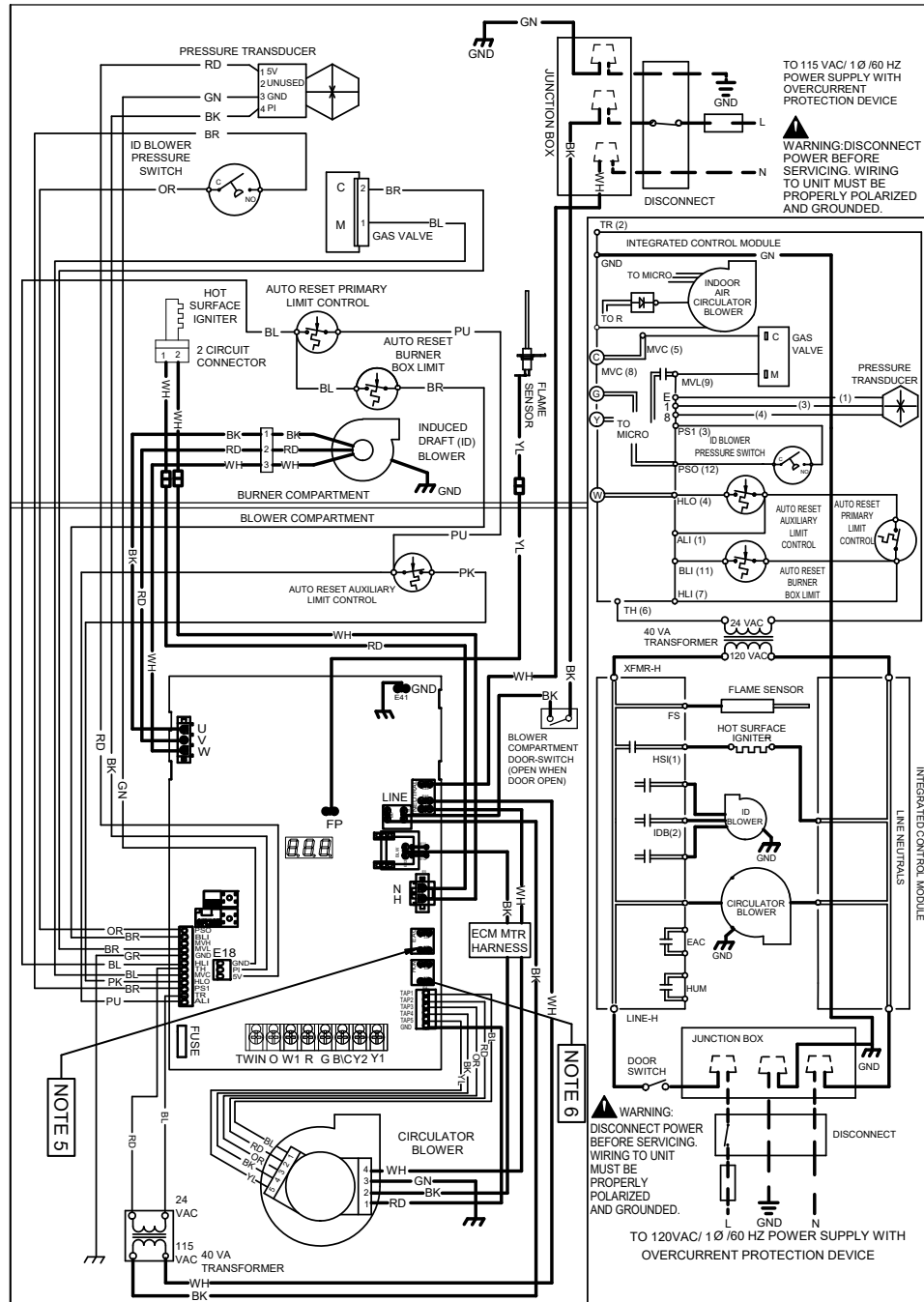

Status & Fault (see installation manual for complete list of faults)	Seven Segment Display		
	Seg. 1	Seg. 2	Seg. 3
Idle	1	d	L
Continuous fan	F	A	n
Low Stage Cooling	1	A	C
High Stage Cooling	2	A	C
Gas Heat		g	H
HP Heat, Low Stage	1	H	P
HP Heat, High Stage	2	H	P
Defrost	d	F	t
Lockout Due to Excessive Retries Recycle	E	E	0
Pressure Switch Closed When Expected To Be Open	E	E	1
Pressure Switch Open When Expected To Be Closed	E	E	2
Open High Limit Switch	E	E	3
Flame Detected When No Flame Should Be Present	E	E	4
Open Fuse	E	E	5
Low Flame Signal	E	E	6
Ignitor Fault Or Ignitor Relay Fault	E	E	7
Reversed Line Polarity	E	E	A
Grounding Error	E	1	0
Internal Gas Valve Error	E	E	b
External Gas Valve Error	E	E	C
Aux Limit Switch Open	E	E	d
Burner Limit Switch Open	E	1	I

NOTES:	1. MANUFACTURER'S SPECIFIED REPLACEMENT PARTS MUST BE USED WHEN SERVICING.
	2. IF ANY OF THE ORIGINAL WIRE AS SUPPLIED WITH THE FURNACE MUST BE REPLACED, IT MUST BE REPLACED WITH WIRING MATERIAL HAVING A TEMPERATURE RATING OF AT LEAST 105°C. USE COPPER CONDUCTORS ONLY.
	3. BLOWER SPEEDS SHOULD BE ADJUSTED BY INSTALLER TO MATCH THE INSTALLATION REQUIREMENTS SO AS TO PROVIDE THE CORRECT HEATING TEMPERATURE RISE AND THE CORRECT COOLING CFM.
	4. UNIT MUST BE PERMANENTLY GROUNDED AND CONFORM TO N.E.C. AND LOCAL CODES.
	5. EAC, NORMALLY OPEN CONTACTS FOR OPTIONAL ELECTRONIC AIR CLEANER USE. CONTACTS CLOSE WHEN INDOOR BLOWER IS RUNNING. TERMINALS ARE NOT INTERNALLY POWERED.
	6. HUM, NORMALLY OPEN CONTACTS FOR OPTIONAL HUMIDIFIER USE. CONTACTS CLOSE WHEN DRAFT INDUCER IS RUNNING. TERMINALS ARE NOT INTERNALLY POWERED.

EQUIPMENT GND	
FIELD GND	
FIELD SPLICE SWITCH (TEMP.)	
IGNITER SWITCH (PRESS.)	
OVERCURRENT PROT. DEVICE	
LOW VOLTAGE (24V)	
LOW VOLTAGE FIELD	
HI VOLTAGE (120V)	
HI VOLTAGE FIELD	
INTERNAL TO INTEGRATED CONTROL	
PLUG CONNECTION	
JUNCTION	
TERMINAL	
OUTPUT	

COLOR CODES:

BK BLACK	GY GRAY	RD RED
BL BLUE	OR ORANGE	WH WHITE
BR BROWN	PK PINK	YL YELLOW
GR GREEN	PU PURPLE	

Wiring is subject to change. Always refer to the wiring diagram on the unit for the most up-to-date wiring.

CUSTOMER FEEDBACK

We are very interested in all product comments.

Please fill out the feedback form on one of the following links:

Goodman® Brand Products: (<http://www.goodmanmfg.com/about/contact-us>).

Amana® Brand Products: (<http://www.amana-hac.com/about-us/contact-us>).

You can also scan the QR code on the right for the product brand you purchased to be directed to the feedback page.



GOODMAN® BRAND



AMANA® BRAND