



**HIGH-EFFICIENCY
CAST IRON BOILER**

CGaTM



Now with built-in low water cut off
Ideal for residential and commercial installations
Durable cast iron design for long service life
Built by North America's leading boiler manufacturer



DIMENSIONS

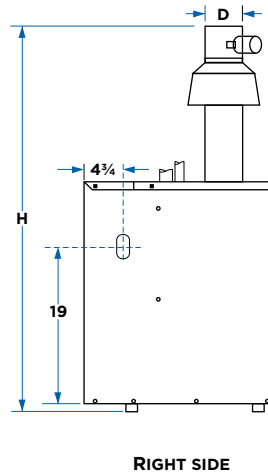
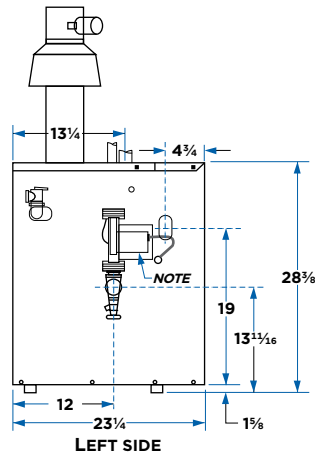
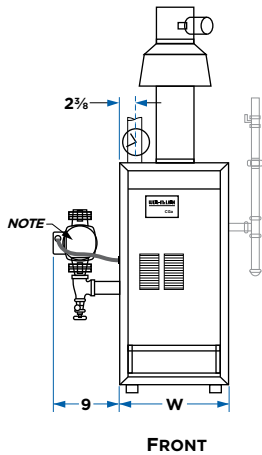
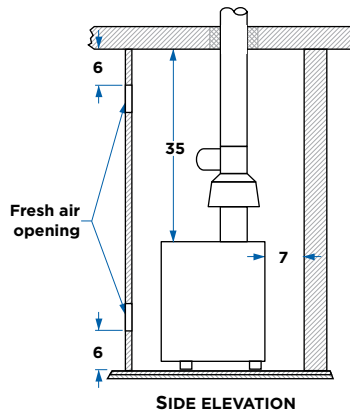
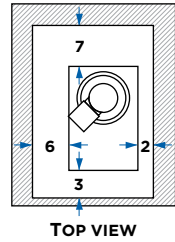
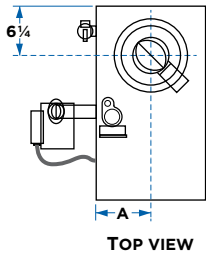

Note: Boiler circulator is shipped loose. Circulator may be mounted on either boiler supply or return piping. See dimension chart for pipe size of circulator flange provided.

Model	Dimensions (in.)				Supply Piping (in.) ¹	Return Piping (in.) ¹	Nat or LP Gas Connection Size (in.)	Carton Dimensions - Outside Measurements (in.)		
	A	D	W	H				L	W	H
CGa-25	5	4	10	45 $\frac{3}{8}$	$\frac{3}{4}$	$\frac{3}{4}$	$\frac{1}{2}$	30	27 $\frac{1}{2}$	35
CGa-3	5	4	10	52 $\frac{3}{8}$	1	1	$\frac{1}{2}$	30	27 $\frac{1}{2}$	35
CGa-4	6 $\frac{1}{2}$	5	13	54 $\frac{3}{8}$	1	1	$\frac{1}{2}$	30	27 $\frac{1}{2}$	35
CGa-5	8	6	16	57 $\frac{3}{8}$	1	1	$\frac{1}{2}$	36	27 $\frac{1}{2}$	35
CGa-6	9 $\frac{1}{2}$	6	19	60 $\frac{3}{8}$	1 $\frac{1}{4}$	1 $\frac{1}{4}$	$\frac{1}{2}$	42	27 $\frac{1}{2}$	35
CGa-7	11	7	22	62 $\frac{1}{2}$	1 $\frac{1}{4}$	1 $\frac{1}{4}$	$\frac{3}{4}$	42	27 $\frac{1}{2}$	35
CGa-8	12 $\frac{1}{2}$	7	25	64 $\frac{3}{8}$	1 $\frac{1}{2}$	1 $\frac{1}{2}$	$\frac{3}{4}$	42	27 $\frac{1}{2}$	35

¹Circulator flange supplied with boiler is the same size as recommended pipe size. For supply and return boiler tapping size, see installation manual.

RATINGS

Model ²	Input MBH ³	DOE Heating Capacity MBH ³	Net AHRI Water Ratings MBH ⁴	AFUE	Approx. Shipping Weight (Lbs.)	Boiler Water Content (Gal.)	Chimney Size
CGa-25	38	32	27	84.0%	200	1.5	4" I.D. x 20'
CGa-3	67	56	48	84.0%	200	1.5	4" I.D. x 20'
CGa-4	100	85	73	84.0%	240	2.1	5" I.D. x 20'
CGa-5	133	113	98	84.0%	280	2.7	6" I.D. x 20'
CGa-6	166	141	122	84.0%	325	3.3	6" I.D. x 20'
CGa-7	200	170	147	84.0%	370	3.8	7" I.D. x 20'
CGa-8	233	198	172	84.0%	425	4.4	7" I.D. x 20'

CGa boilers are C.S.A. design certified for installation on combustible flooring. Tested for 50 PSI working pressure.

STANDARD EQUIPMENT:

BOILER

- Integrated Boiler Control Module with intermittent electronic ignition system & indicator/diagnostic lights
- Integrated low-water cutoff, with test button
- Two-piece top jacket panel
- Insulated extended steel jacket
- Cast iron sections with built-in air separator
- Radiation plates
- Vertical draft hood
- Automatic vent damper
- Combination gas valve for 24 volt
- Wiring harness
- Non-linting pilot burner
- Stainless steel burners
- Electrical junction box
- Rollout thermal fuse element
- High-limit temperature control
- Circulator (when ordered)
 - Sizes 25-5: Taco 007e
 - Sizes 6-8: Taco 007
- Spill switch
- 30 PSI ASME relief valve (boiler sections tested for 50 PSI working pressure)
- Combination pressure-temperature gauge
- Drain valve
- 40 VA transformer
- Plug-in connector and wiring

ADDITIONAL EQUIPMENT:

- Expansion tank package — shipped in separate carton (expansion tank, fill & check valve, auto air vent and fittings)
- Outdoor Reset Kit (part #381-356-586) Low cost, simple plug-in sensor—check local utility program for possible rebate.
- Zone Interface Harness Kit (part #381-356-585) Used to communicate between an existing relay panel wired into the system and boiler, to separate DHW from space heating demands.

LIMITED TRANSFERABLE

WARRANTY:

- Residential: 20 Years Heat Exchanger; 2 Years Parts
- Commercial: 10 Years Heat Exchanger; 1 Year Parts

²Add "PIN" for natural gas, "PIL" for propane.

³Based on standard test procedures prescribed by the United States Department of Energy.

⁴Net AHRI ratings are based on net installed radiation of sufficient quantity for the requirements of the building and nothing needs to be added for normal piping and pick-up. Ratings are based on a piping and pick-up allowance of 1.15. An additional allowance should be made for unusual piping and pick-up loads.



ENGINEERED, DESIGNED & ASSEMBLED in the USA