



Submittal Data Sheet
 1.25-Ton Wall Mounted with Heat Pump
 FTX15WMVJU9RXL15WMVJU9

Model	Indoor Unit		FTX15WMVJU9	
	Outdoor Unit		RXL15WMVJU9	
			Cooling	Heating
Power Supply		1 ϕ , 208 - 230 V, 60 Hz		
Capacity Rated (Min. - Max.)	Btu/h	15,000 (5,800 - 18,400)	18,300 (5,800 - 24,600)	
Running Current (Rated)	A	6.42 - 5.81	7.24 - 6.55	
Power Consumption (Rated)	W	1,250 - 1,250	1,426 - 1,426	
Power Factor (Rated)	%	93.6 - 93.5	94.7 - 94.6	
SEER2 / HSPF2		19.50	10.00	
EER2 (Rated)	Btu/h·W	12.00	—	
COP2 (Rated)	W/W	—	3.76	
Piping Connections	Liquid	in. (mm)	ϕ 1/4 (6.4)	
	Gas	in. (mm)	ϕ 1/2 (12.7)	
	Drain	in. (mm)	ϕ 5/8 (16)	
Heat Insulation		Both Liquid and Gas Pipes		
Max. Interunit Piping Length	ft (m)	98-1/2 (30)		
Max. Interunit Height Difference	ft (m)	65-5/8 (20)		
Chargeless	ft (m)	32-3/4 (10)		
Amount of Additional Charge of Refrigerant	oz/ft (g/m)	0.21 (20)		
Indoor Unit		FTX15WMVJU9		
Front Panel Color		White (N9.5)		
Airflow Rate	H / M / L / SL	cfm	593/ 505 / 431 / 367	
		m3/min	16.8 / 14.3 / 12.2 / 10.4	
			653 / 554 / 470 / 399	
Fan	Type / Speed	Steps	Cross Flow Fan / 5 Steps, Quiet, Auto	
Air Direction Control		Right, Left, Horizontal, Downward		
Air Filter		Removable, Washable		
Running Current (Rated)	A	0.23 - 0.21	0.25 - 0.23	
Power Consumption (Rated)	W	33 - 33	38 - 38	
Power Factor (Rated)	%	69.0 - 68.3	73.1 - 71.8	
Temperature Control		Microcomputer Control		
Dimensions (H \times W \times D)	in. (mm)	11-5/8 \times 39 \times 10-3/8 (295 \times 990 \times 263)		
Packaged Dimensions (H \times W \times D)	in. (mm)	15-3/16 \times 43-3/8 \times 15-5/16 (386 \times 1,102 \times 389)		

Daikin Comfort Technologies North America, Inc 19001 Kermier Rd Waller TX 77484
 Daikin City Generated Submittal Data www.daikincomfort.com or www.daikinac.com

(Daikin's products are subject to continuous improvements. Daikin reserves the right to modify product design, specifications, and information in this data sheet without notice and without incurring any obligations)



Submittal Data Sheet
 1.25-Ton Wall Mounted with Heat Pump
 FTX15WMVJU9RXL15WMVJU9

Weight (Mass)		lbs (kg)	27 (13)	
Gross Weight (Gross Mass)		lbs (kg)	36 (17)	
Sound Pressure Level	H / M / L / SL	dB(A)	45 / 41 / 36 / 33	45 / 41 / 37 / 33
Outdoor Unit		RXL15WMVJU9		
Casing Color		Ivory White		
Heat Exchanger	Fin Spec / Tube		Waffle Fin (PE) / φ 7 Hi-XSL Tube	
Fan Motor	Motor Output	HP	0.12	
Compressor	Type		Hermetically Sealed Swing Type	
	Model		2YC36PXD	
Refrigerant Oil	Type		FVC50K	
	Charge	oz (L)	21.98 (0.650)	
Refrigerant	Type		R-410A	
	Charge	lbs (kg)	3.20 (1.45)	
Airflow Rate		cfm (m3/min)	2,044 (57.9)	2,044 (57.9)
Fan	Type		Propeller	
Running Current (Rated)		A	6.19 - 5.60	6.99 - 6.32
Power Consumption (Rated)		W	1,217 - 1,217	1,388 - 1,388
Power Factor (Rated)		%	94.5 - 94.5	95.5 - 95.5
Dimensions (H × W × D)		in. (mm)	28-15/16 × 34-1/4 × 12-5/8 (735 × 870 × 320)	
Packaged Dimensions (H × W × D)		in. (mm)	31-7/8 × 41-9/16 × 18-1/4 (810 × 1,056 × 464)	
Weight (Mass)		lbs (kg)	109 (50)	
Gross Weight (Gross Mass)		lbs (kg)	119 (54)	
Sound Pressure Level		dB(A)	50	55
Conditions Based on	Indoor		80.0°FDB (26.7°CDB) / 67.0°FWB (19.4°CWB)	70.0°FDB (21.1°CDB) / 60.0°FWB (15.6°CWB)
	Outdoor		95.0°FDB (35°CDB) / 75.0°FWB (24.0°CWB)	47.0°FDB (8.3°CDB) / 43.0°FWB (6.1°CWB)
	Piping Length		25 ft (7.5 m)	
Note(s)		SL: The quiet fan level of the airflow rate setting.		

Daikin Comfort Technologies North America, Inc 19001 Kermier Rd Waller TX 77484
 Daikin City Generated Submittal Data www.daikincomfort.com or www.daikinac.com

(Daikin's products are subject to continuous improvements. Daikin reserves the right to modify product design, specifications, and information in this data sheet without notice and without incurring any obligations)

4. Dimensions

4.1 Indoor Unit FTX09/12WMVJU9

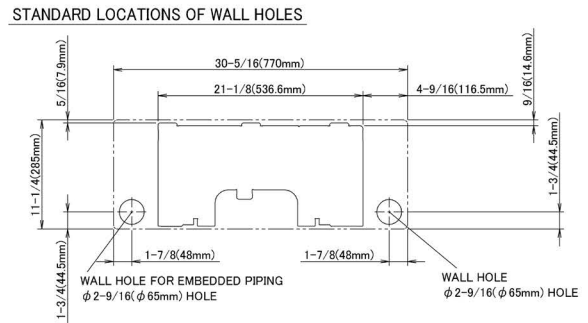
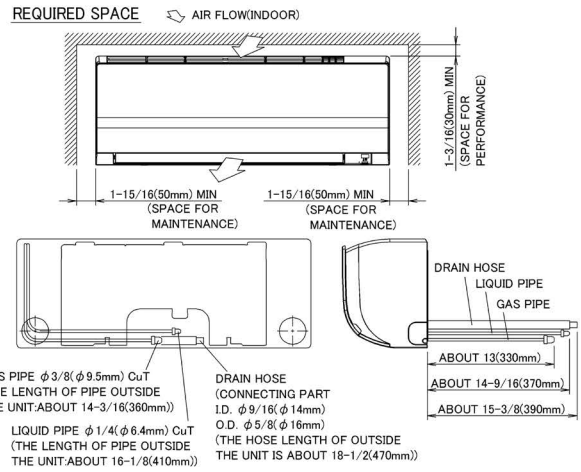
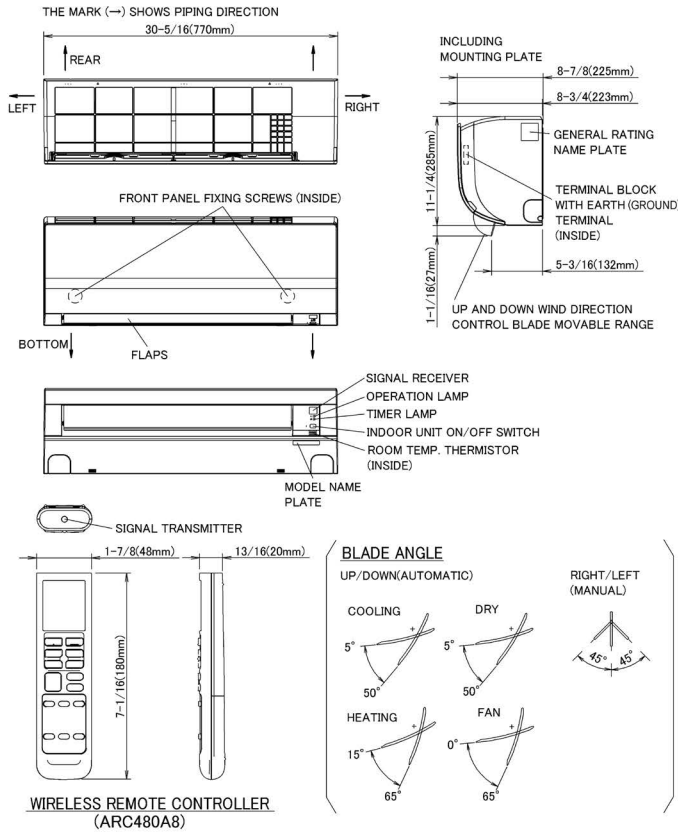

C: 3D091702A

FTX15WMVJU9

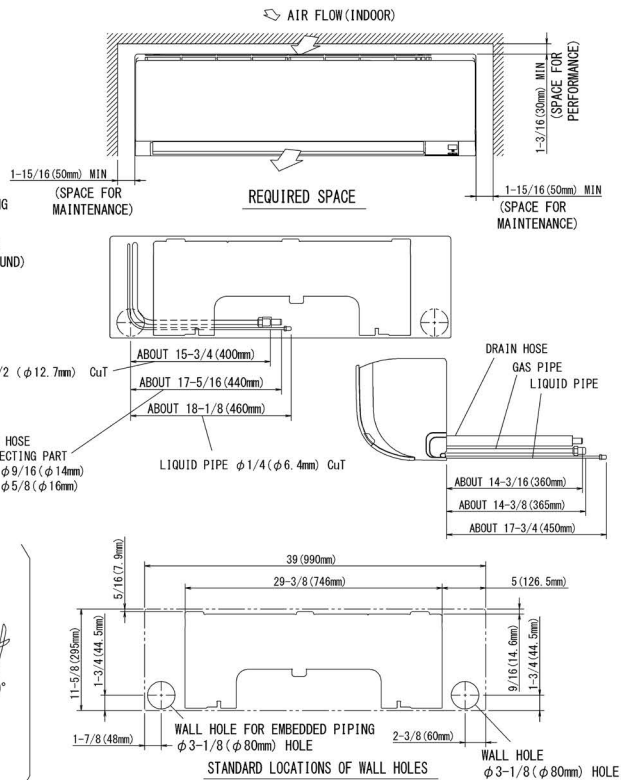
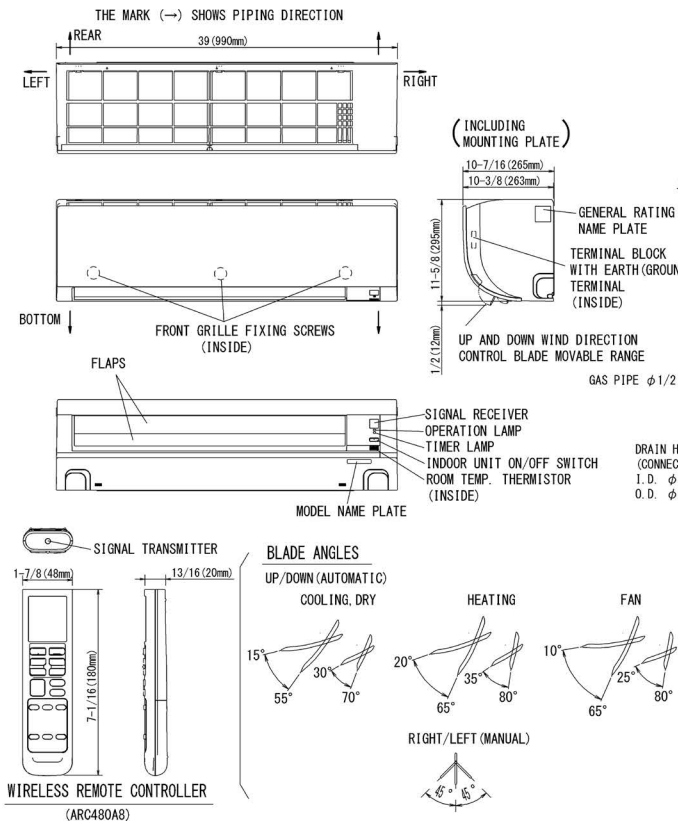

3D091779C

4.2 Outdoor Unit RXL09/12WMVJU9

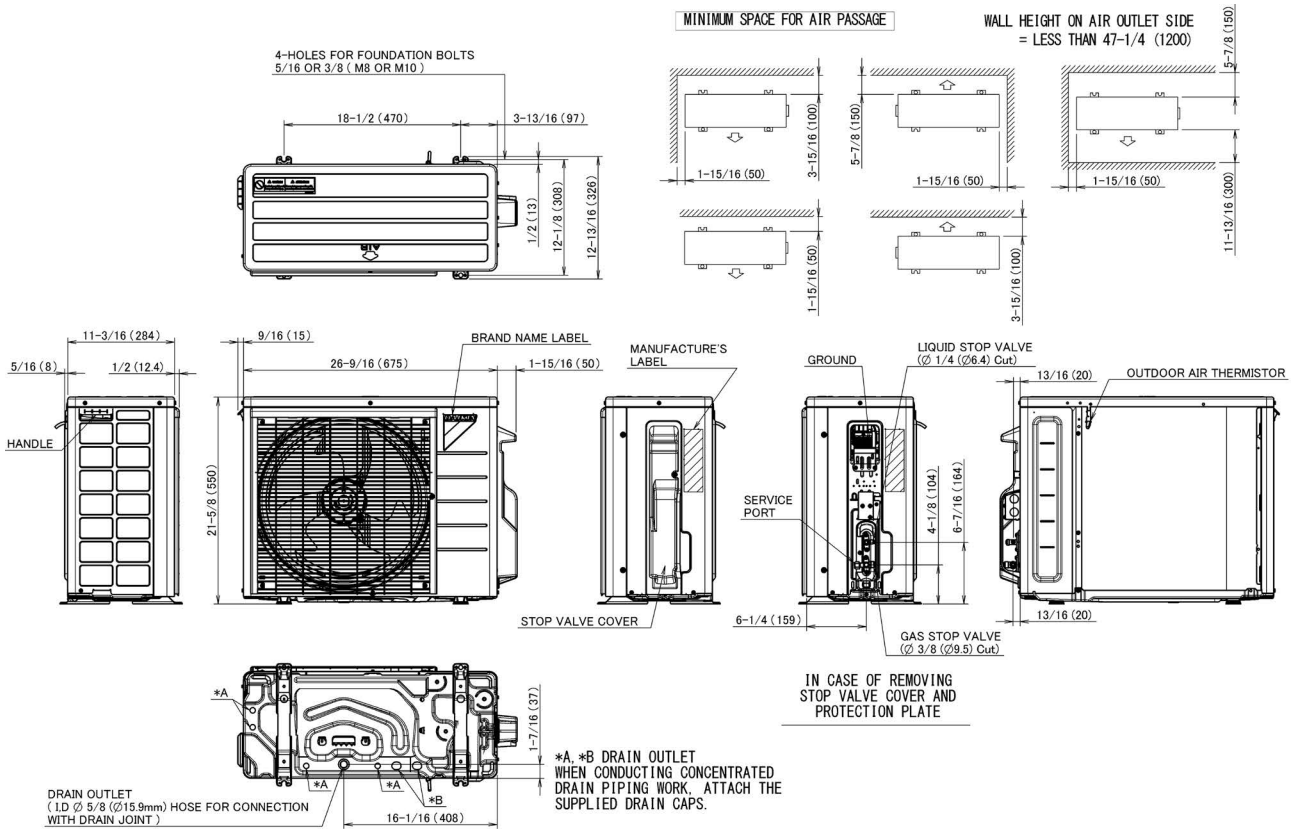

3D136777

RXL15WMVJU9

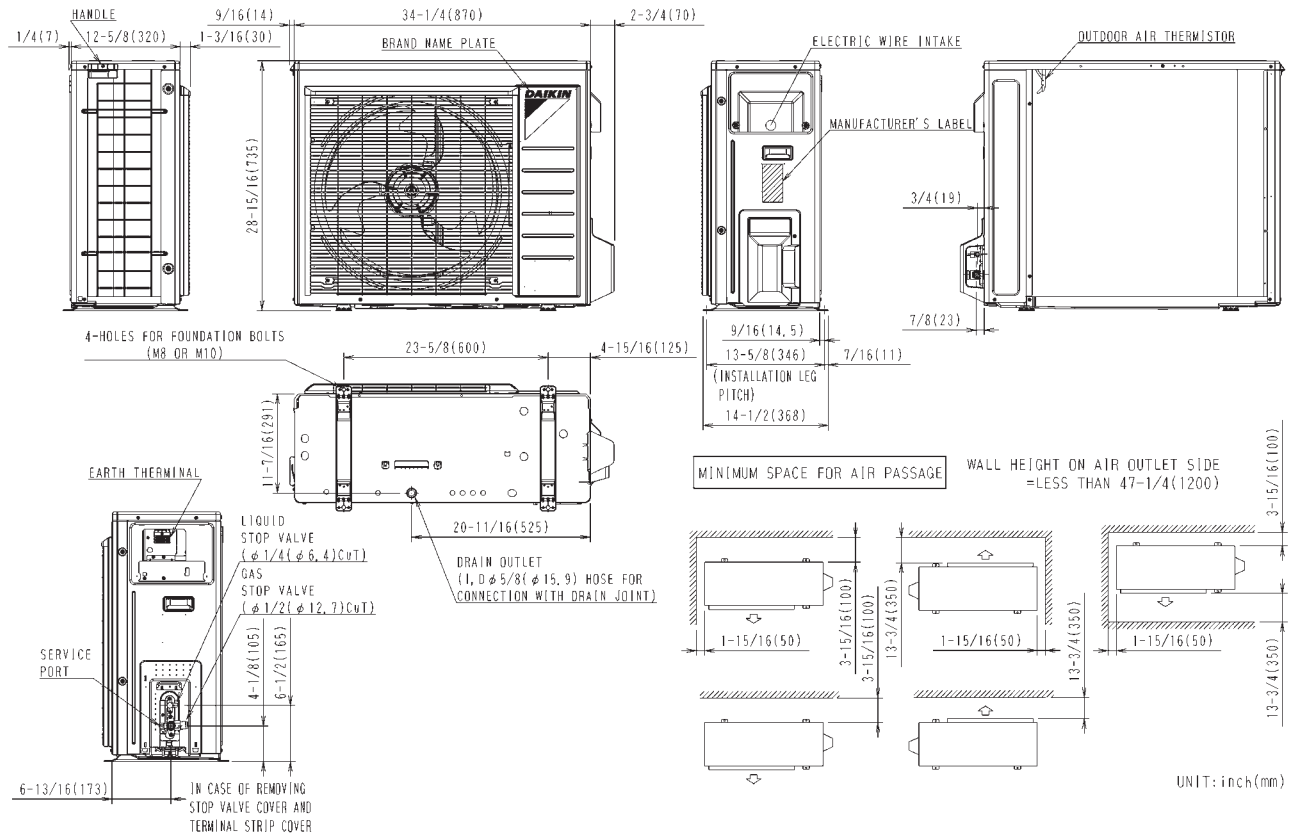

3D092224D

11. Electric Characteristics

Indoor Unit	Outdoor Unit	Power Supply				Compressor	OFM			IFM		
		Hz - Volts	Voltage Range	MCA	MFA		RLA	Hp	W	FLA	Hp	W
FTX09WMVJU9	RXL09WMVJU9	60 Hz - 208 V 60 Hz - 230 V	Max. 60 Hz, 253 V Min. 60 Hz, 187 V	8.7	15	8.5	0.03	23	0.19	0.03	21	0.20
FTX12WMVJU9	RXL12WMVJU9	60 Hz - 208 V 60 Hz - 230 V	Max. 60 Hz, 253 V Min. 60 Hz, 187 V	12.2	15	12.0	0.04	27	0.21	0.04	28	0.23
FTX15WMVJU9	RXL15WMVJU9	60 Hz - 208 V 60 Hz - 230 V	Max. 60 Hz, 253 V Min. 60 Hz, 187 V	12.2	15	12.0	0.12	93	0.58	0.05	33	0.23
FTX18WVJU9	RXL18WMVJU9	60 Hz - 208 V 60 Hz - 230 V	Max. 60 Hz, 253 V Min. 60 Hz, 187 V	18.6	20	18.3	0.16	122	0.77	0.07	48	0.37
FTX24WVJU9	RXL24WMVJU9	60 Hz - 208 V 60 Hz - 230 V	Max. 60 Hz, 253 V Min. 60 Hz, 187 V	18.8	20	18.3	0.16	122	0.77	0.07	48	0.57
FVXS09WVJU9	RXL09WMVJU9	60 Hz - 208 V 60 Hz - 230 V	Max. 60 Hz, 253 V Min. 60 Hz, 187 V	8.7	15	8.5	0.03	23	0.19	0.02	12	0.21
FVXS12WVJU9	RXL12WMVJU9	60 Hz - 208 V 60 Hz - 230 V	Max. 60 Hz, 253 V Min. 60 Hz, 187 V	12.2	15	12.0	0.04	27	0.21	0.02	13	0.22
FVXS15WVJU9	RXL15WMVJU9	60 Hz - 208 V 60 Hz - 230 V	Max. 60 Hz, 253 V Min. 60 Hz, 187 V	12.3	15	12.0	0.12	93	0.58	0.03	23	0.29
FDMQ12WVJU9	RXL12WMVJU9	60 Hz - 208 V 60 Hz - 230 V	Max. 60 Hz, 253 V Min. 60 Hz, 187 V	12.6	15	12.0	0.04	27	0.21	0.17	130	0.63
FDMQ18WVJU9	RXL18WMVJU9	60 Hz - 208 V 60 Hz - 230 V	Max. 60 Hz, 253 V Min. 60 Hz, 187 V	19.1	20	18.3	0.16	122	0.77	0.31	230	0.84
FDMQ24WVJU9	RXL24WMVJU9	60 Hz - 208 V 60 Hz - 230 V	Max. 60 Hz, 253 V Min. 60 Hz, 187 V	19.3	20	18.3	0.16	122	0.77	0.31	230	1.10

Symbols:

- MCA : Min. circuit amps (A)
- MFA : Max. fuse amps (A)
- RLA : Rated load amps (A)
- OFM : Outdoor fan motor
- IFM : Indoor fan motor
- FLA : Full load amps (A)
- W / Hp : Fan motor rated output (W, Hp)

Notes:

1. RLA is the max current that comes in cooling operation and heating operation.
2. Maximum allowable voltage variation between phases is 2%.
3. Select wire size based on the larger value of MCA.

C: 3D143137
C: 3D143133A